

Brookshire Economic Development Corporation

THE STATE OF TEXAS }
CITY OF BROOKSHIRE }
COUNTY OF WALLER }

NOTICE IS HEREBY GIVEN OF A REGULAR MEETING OF THE BROOKSHIRE ECONOMIC DEVELOPMENT CORPORATION TO BE HELD THURSDAY, APRIL 2, 2026, AT 6:00 P.M., IN THE COUNCIL CHAMBERS OF THE BROOKSHIRE MUNICIPAL BUILDING 4029 FIFTH STREET, BROOKSHIRE, TEXAS, FOR THE PURPOSE OF CONSIDERING THE FOLLOWING AGENDA ITEMS:

AGENDA

1. Call to order.
2. Prayer.
3. Pledge to the U.S. Flag.
4. Roll Call.
5. Public Comments.

Comments made under this agenda item are limited to five (5) minutes per person; however, if a large quantity of individuals has registered to speak, the time may be reduced at the chair's discretion. In accordance with the Texas Open Meetings Act, the board of Directors will not discuss or consider any items addressed during this agenda item. However, the President or Economic Development coordinator may make statements of fact, for example, identifying the procedure for reporting an issue or referring the speaker to the cognizant agency or individual.

6. Discussion and possible action to approve BEDC minutes for March 5, 2026
7. Discussion and possible action to approve March 2026 Financial Report.
8. Discussion and possible action to consider the use of sales tax proceeds to undertake and to fund improvements and development of greenspace at Hovas Park (concrete around baseball fields) and the Amphitheater (light poles and fixtures). (Estimated value: ~\$226,000.00)
9. Discussion and possible action on landscaping in front of the Welcome rock on FM 359 S. (Michael Kosar)
10. Discussion on the date for the Business and Expansion program. (Deniece Odie)
11. Discussion and possible action to purchase the Everest LED Solar Lamps for Hwy. 90. (Deniece Odie)
12. Discussion and possible action creating a budget line item for BEDC events. (Deniece Odie)
13. Discussion and possible action to set a date to tour the La Segarra Community hosted by Smith Douglas Homes. (Dr. Bautista)
14. Discussion and possible action to approve the BEDC Policy and Procedures manual. (Dr. Bautista)
15. Project Managers Report. (Dr. Bautista)
16. Future Agenda Items.
17. Executive Session.

The Brookshire Economic Development Corporation will meet in a closed session pursuant to Title 5, Chapter 551, of the Texas Government Code for the purpose of: Economic Development Discussions under Section 551.087; Consultation with legal counsel under Section 551.071; and Deliberations on real property under Section 551.072."

18. Discussion and possible action on Executive Session items if necessary.
19. Adjournment.

A quorum of the Brookshire City Council may be present, but no official action will be taken by the Council.

Note: In compliance with the American with Disabilities Act, this facility is wheelchair accessible and accessible parking spaces are available. Requests for accommodations or interpretive services must be made at least 48 business hours prior to this meeting. Please contact the city secretary's office at 281-375-5050 for further information.

I, *Vickie Casto*, do hereby certify that the above Notice of Meeting and Agenda of the Brookshire Economic Development Corporation was posted in a place convenient and readily accessible at all times to the general public in compliance with Chapter 551, TEXAS GOVERNMENT CODE, March 27, 2026, at 2:15 PM



Administrative Assistant to the Board of Directors

Minutes of the Brookshire Economic Development Corporation Meeting
March 6, 2026

The Brookshire Economic Development Corporation held a Special Meeting on Thursday, March 5, 2026, in the Brookshire Municipal Building located at 4029 Fifth Street, Brookshire, Texas.

Agenda Item #1: Call to order.

The meeting was called to order by President, Eric Green at 6:00 p.m.

Agenda Item #2: Prayer.

Director, Lyndon Stamps

Agenda Item #3: Pledge to the U. S. Flag.

Everyone

Agenda Item #4: Roll Call.

Present:

President, Eric Green

Vice-President, Deniece Odie

Secretary/Treasurer, Michael Kosar

Director, Lyndon Stamps

Director, Nathaniel Richardson

Director, Amber Allison

Absent: Director, Rodney Blouin

Also Present:

Attorney, David Olson

Project Manager, Ramiro Bautista

BEDC Administrative Assistant, Vickie Casto

Agenda Item #5: Public Comments.

N/A

Agenda Item #6: Discussion and possible action to approve BEDC minutes for February 5, 2026

Motion was made to approve the BEDC minutes for February 5, 2026, with correction if any.

Director, Lyndon Stamps / Secretary / Treasurer, Michael Kosar

All For
Motion Carried

Agenda Item #7: Discussion and possible action to approve January 2026 and February 2026 Financial Report.

Motion was made to approve January 2026 and February 2026 Financial Report.

Director, Lyndon Stamps / Director, Amber Allison

All For
Motion Carried

Agenda Item # 8: Public Hearing:

- a. Public Hearing concerning the following proposed BEDC Type B Projects
Hovas Park (concrete around baseball fields) and the Amphitheater lights.
Estimated \$226,000.00

President Green opened the Public Hearing at 6:03 p.m.

Dr.. Bautista addressed the board and stated that last month they had another public hearing for their other type B projects for the development of green space. He's now received the quotes for these last two, so he can bring them back to the board and to the public and identify the last two projects.

They are the baseball fields and the fences around the fields at Hovas park.

The light poles and fixtures here at the amphitheater. He then did a presentation to show them the locations and what they would look like. He then spoke of the type of lights and wattage at the amphitheater and where they would be located.

He then spoke on the three backup generators, one at the annex building, one at the disaster center and one at public works building.

Mr. Green asked if the price was just for the four poles and lights, there's nothing on the amphitheater itself?

Mr. Olson stated they were in the middle of the public hearing, see if anybody else wants to speak on it, then when they get to the next item, they can get into those questions.

Mr. Green asked if there were any more questions.

Mr. Green then closed the public hearing at 6:10 p.m.

Agenda Item #9: Discussion and possible action to consider the use of sales tax proceeds to undertake and to fund improvements and development of greenspace at Hovas Park (concrete around baseball fields) and the Amphitheater (light poles and fixtures). (Estimated value: \$226,000.00)

Mr. Green stated he saw the four poles listed; but are there any lights on the amphitheater.

Dr.. Bautista stated his understanding they wouldn't be necessary based on the light that's coming from the light poles. The 30' light pools will go somewhere between 8 and 10 feet down and have concrete down in each.

He thinks this probably is a third of that cost.

Mr. Green asked if there were any more questions or discussion. If not, he would entertain a motion.

Dr. Bautista stated he wanted to add one last thing. This will also go to the city council agenda tonight if approved.

Motion was made to use the sales tax proceeds to undertake and fund improvements and development of green space at Hovas Park, concrete around baseball fields and amphitheater light poles and fixtures. Estimated value, \$226,000.00.

Director, Lyndon Stamps
President, Eric Green stated no second, motion failed.

Agenda Item #10: Presentation:

- a. Potential 3-day Small Business Bootcamp. (*Erika Jones Extension Agent PVAMU*)

Dr. Bautista stated that they had a brief presentation for them for a potential boot camp hosted here at the convention center. He wanted to bring it to them as the city's taken some consideration in the boot camp as well. Based off the outcome tonight of this agenda item, then the city can identify what the contributions will be as well.

Ms. Jones introduced herself. She is the community economic development extension agent for Prairie View, and she's assigned to Waller County. She is presenting a two-to-three-day small business boot camp. This boot camp was started last year in Waller County; it's a nine-day camp. It's for nine days, two hours a day and the last day is four hours. The boot camp that is designed for Brookshire will be a different spin because they will accommodate more of what is happening in the industry with the comptroller. She explained what was going on with the comptroller. The hub has been removed, and lot of their business owners don't know where that climate is directing. With the growth that's taking place here in Brookshire and Waller County, they want to keep the dollars here in the county. To better educate the small business owners on how to obtain government contracts, they will have the program. She has been dealing with Metro, the port, Eric Davis with Edward Jones so they do have some good viable information. Last year she graduated 19 small business owners from her academy, and out of those 19 she helped six to submit government contracts. As extension agents they do technical assistance, they follow their small business owners. After the academy she monitors the small business owners. She knows that pricing is an issue with the owners as they don't understand how to price bids. She then spoke of a couple other programs such as grant and bid writing.

This academy will be in days. The first day will be foundational readiness, making sure that business is aligned properly and in position to obtain government contracting. They will take them through business structure, compliance essentials, financial readiness, bookkeeping and understanding the procurement process.

Day two is competitive strategy and cooperative purchasing. Her goal is to have a cooperative purchasing here. Supply diversity opportunities, last year the port came and presented bid opportunities as well as Metro. They will offer bid proposals writing fundamentals, strategic partnership. She will be going to a conference next month that will give her the ability to speak to them face to face.

Day three focuses on pricing, understanding overhead margins and risks that are common mistakes in small business. A lot of small businesses don't know when to exit, they don't know how to position their businesses to sell and just close down. They'll have Edward Jones to come in and talk about the strategies of business owners.

She believes this boot camp will help the businesses stay here and eliminate some of the shrinkage.

Mr. Richardson asked if she was affiliated with the university or the city.

Ms. Jones stated she was affiliated with Prairie View Corporate Extension. Somer of their positions funded 100% through the university. Some have different percentage allocations throughout the county. She works for the county as well as Prairie View.

Mr. Richardson addressed the attorney and stated the reason for the questions was because he worked for Prairie View and he didn't want this to be a conflict of interest if he votes for or against.

Mr. Olson asked if they were hiring at Prairie View A&M or were they hiring a separate third-party consultant?

Ms. Jones replied that it's a third-party consultant.

Mr. Olson said it's not going to be a conflict.

Mrs. Allison stated she looked over the details and there is an estimated attendance of 30-50 participants at an estimate of 8,000. Then asked would she make an adjustment based on what ... what if only 15 attended?

Ms. Jones replied, absolutely. She then stated on #6, if there's an extended impact on use of remaining funds, she did give a plan of action on additional funding.

Mrs. Allinson wanted to know in her next class was she going to base it contingently on whether

Ms. Jones stated that she had this for July 8th through 10th, and she is also asking to utilize the Brookshire Convention Center.

Mrs. Allinson asked how she planned to market to the community. Was she knocking on doors or would she already have a presence with different associations?

Ms. Jones said she already had 31 registered. One thing she does is market.

Mrs. Allinson said she was impressed that she already had some commitment.

Ms. Jones added that most of her participants from last year were on her program area committee. As she is here tonight, three of her class members, Truist Bank sponsor and two of her class members are running her class right now.

Agenda Item #11: Discussion and possible action to fund the Small Business Bootcamp.

Motion was made to approve the fund for the Small Business Bootcamp for \$8,000.00.

Director, Lyndon Stamps / Secretary-Treasurer, Michael Kosar

Mr. Olson said before they vote, he thinks part of the request was and he's not sure if the EDC even has the authority for the waiver of the convention center rental fees; but it could be part of their recommendation to the council.

Dr. Bautista said the city has put a placeholder for that event based on their meeting that they would come to them to see if it was going to get funded first.

Mr. Olson asked, was the intention to wave fees?

Dr. Bautista replied, correct.

Mr. Olson concluded that it was not needed and added that the motion stands as stated, they could vote on it as it is done.

All For
Motion Carried

Agenda Item #12: Discussion and possible action to approve the BEDC Policy and Procedures manual. (Dr. Bautista)

Dr. Bautista stated at the last meeting he was asked to produce this so he's bringing it forward. Based off board meeting policies and procedures, governance policies and procedures, entertainment policies and procedures and financials how they occur here within the organization. So, this solidifies the request that was given.

Mrs. Allison said she wanted to know, based on this it's stating 2026 to 2028 ... were there any modification from the prior year policies and procedures that was modified to...

Mr. Bautista stated this was the initial version.

Mrs. Allison said that's what she wanted to know.

Dr. Bautista added that there weren't any prior to.

Mrs. Odie asked if they were making an amendment.

Dr. Bautista again stated that this was the initial version.

Mr. Olson said they were adopting a new policy.

Mrs. Odie confirmed that the policy that they have in their ... as she was looking in her papers, she asked if one was the policy.

Dr. Bautista asked if that was the articles of incorporation.

Mr. Olson went to see what Mrs. Odie was referring to. He stated it was just the mission statement and goals. That it's not really a policy, it's just part of their overall general purpose. This is more detailed, working through procedurally how you handle all steps from agenda to passing ordinances and your other obligations and authorizing types of projects.

Mrs. Odier stated that Mr. Richardson asked about Robert's rules of order when we were at the last meeting. Is that correct?

Mr. Richardson replied yes.

Mrs. Odie then asked if this policy and procedure was based on Robert's rules of order.

Mr. Olson replied no and added it just requires or gives authority to the chair to maintain decorum. They can adopt necessary policies ... probably not necessary unless it becomes an issue. But this doesn't really adopt by inference Roberts rules or anything similar to that. It really gives them the discretion to adopt those types of decorum rules as they see fit.

Mr. Richardson wanted to know if it had been vetted by them.

Mr. Olson said that he did look at it. It's very broadly written; but he thinks it's a great start and if they see any issues in any of these areas, it's a living and breathing document, so they can address it; but it's not inconsistent with the other policies for EDCs that he's seen.

Mrs. Odie said in some places it says the director. Who is the director?

Mr. Olson said he thought they were looking at him.

Mrs. Odie asked if the director head of the president or the president the head of the director?

Dr. Bautista stated he thought there was a board president and then there's a staff member. He's a staff member.

Mr. Olson said the president is a member of the board. The board directs them at the staff level ... Director, your EDC Attorney and everybody else at the staff level. They are sitting at the top and telling us what to do.

Mr. Green said his question was to the board. There are a lot of questions, do they want more time to go through it so they can reach out to him, Mr. Olson or any other board members or Dr. Batista to get better clarity about this?

Mr. Richardson said he thought that would be the prudent thing to do. Just let them have time to look at it. Like the attorney was saying, it just gives them some kind of order and not just doing stuff. He added that it was not his nature and he would like to have some kind of decorum in place that they can hold each other accountable to how they treat each other in a meeting.

Mr. Olson stated he thought that was fair and he would encourage them if they have questions send it to Dr. Batista and he can then send it to Eric or himself to kind of go over this. He told Dr. Batista he assumed he was the point person at the staff level.

Dr. Batista replied yes and added he would be happy to address ...

Mr. Olson added that there was nothing violating the act as long as they don't share it amongst themselves. It gives them a heads up on dealing with the issues on the front end.

Dr. Batista added for them to keep in mind that when they identify and read under the governance policies, under the appointments ... these conflicts of interest... they need a

documented conflict of interest statements from each of them. Even if these aren't passed, they need that documented on file.

Mr. Green stated that they would not take action.

No Action

Agenda Item #13: Discussion and possible action for lighting on Highway 90.

(Deniece Odie)

Mrs. Odie addressed the board and stated she had put this back on the agenda again because it's been on the agenda four or five times. She then addressed Dr. Bautista and stated she went out and drove the street. She directed everyone to their packets to view the pictures she had taken. She went over each picture and explained the location and told how dark it was in that area. She had asked in the last meeting about light for the trees; but then she asked if that easement was part of the railroad.

Dr. Batista stated they were allowed to put trees there as a beautification project.

Mrs. Odie said that there were several lights on that easement that's broken. She did not know those lights were there and then asked Dr. Batista if he knew.

Dr. Batista stated that he did know and they had reported them to Center Point. He added they just need the light pole number and that's usually reported.

Mrs. Odie wanted to know who did the reporting.

Dr. Batista replied, anyone, public works, whoever submits the request.

Mr. Stamps said if a citizen calls it in, they just need the number off the pole.

Mrs. Odie said that there was a pole on each end where the trees are and asked if they were able to install one more pole

Dr. Batista said they could attempt to request Center Point to install those poles. He doesn't know who pays the light on that; but they can always find out.

Mrs. Odie stated if they could do that and get the lights on the trees, she thinks this would brighten up Highway 90. She then spoke on the opposite side of highway 90 which is where her business is but there are other businesses there also. She added that side was also dark and added that Cricket had complained to her because they must leave at nighttime and it's dark. When the lady leaves out, she has money that she has to deposit. She then showed them a light that was in their packets and suggested maybe getting some small ones installed on that side, if possible.

Dr. Batista said let them know what to do and what project and they'll go through the process.

Mr. Green asked to see if it's possible for the decorative light on that sidewalk. He doesn't know how much of an easement they have because he knows that TxDOT is planning on expanding and he has no idea which direction they're going to go. He doesn't know if they will even approve it; but it wouldn't hurt to reach out to them to see if it's possible.

Mrs. Odie also pointed out the doctor's office, and the new snack shop is dark as well.

Dr. Batista stated they were all privately owned facilities.

Mr. Green asked if there was anything in the ordinance that requires building owner to provide lighting.

Dr. Batista said they did put some funding towards a business improvement grant, and those dollars could contribute to maybe a reimbursement for a private owner to install some lights.

Mr. Kosar asked if they could also put that into beautification.

Dr. Batista asked on private property.

Mr. Kosar asked if the sidewalk was private property.

Mr. Olson stated that it was public and added that in this case it's probably state right of way. But even if it's state it's still theirs, it's still going to be public. They can make improvements in the right of way, or private property. Just tell them what you'd like to be done and they'll ...

Mr. Kosar asked, didn't they have a budget set up for beautification?

Mr. Olson replied that beautification is probably for public right of way, he would imagine.

Dr. Bautista let them know that their budget was for type B projects.

Mr. Richardson said that calling it beautification to him is a safety issue if it's that dark which he's projecting. The owner would want to make sure that people who come to patronize them are not going to fall because of the darkness. So, why don't they take that approach from a safety standpoint? They could take on some of the cost or maybe get a report to see what it would cost to put X amount of lights along 90. Only if they can get their permission. Get the cost and then come back and move in that direction.

Mrs. Allison said her question was, would this be a shared expense with the city of Brookshire or strictly economic development?

Mr. Richardson stated that to him it's safety and they have the money. It really doesn't bother him if they pay for it or the business. But they want to stay legal, so they'll forward that to the attorney.

Mr. Olson stated probably not safety; but they can incentivize businesses to help with their façade and general aesthetics of their business, which would include things like lighting. He thinks they can handle it that way.

Dr. Bautista stated that they did put some funding in that program.

Mr. Green then asked if they would like to direct Dr. Bautista to reach out to the business owners to see if they would be interested in going through the program. He then asked the name of the program again.

Dr. Bautista replied, Business Improvement Grant. He added that they would create a application process and some type of development agreement to go in place with that as well.

Mr. Olson said these small business things aren't going to be complicated like some of the other long development agreements. They'll be simple, just measurable goals and funding dependent on those goals being accomplished.

Mr. Richardson asked Mrs. Odie if that would also include her concerns as well.

Dr. Bautista replied yes.

Mr. Olson said he had gotten the impression that they'd not only talked with the small business owners and might reach out to Center Point and also TxDOT might have a problem with it if Center Point is willing to put additional polls in there.

Mr. Green asked if they needed to take action on this.

Mr. Olson said he thought they had the guidance they needed.

No Action

Agenda Item #14: Discussion on lighting on FM 359. (Deniece Odie)

Mrs. Odie said that lighting on 359 has three lights there; but they are very dim. How do they get those bulbs brighter?

Dr. Bautista asked where on 359.

Mrs. Odie stated by the Flying J. She added that once you get to Orlando's Pizza and you're going towards 90, it's pitch dark. She stated that someone has almost gotten hit on a bicycle, and to her understanding there have been two fatalities on 359.

Mr. Kosar stated there was just a bad accident there the other day by that tire store.

Mr. Green asked if there was no light there or just really dim.

Mrs. Odie said there are three lights.

Mr. Green said she needs to be a little more specific about where to find the lights.

Mrs. Odie showed him the location on the picture that was in the packet, and said there were three light poles there but they're not putting off a lot of light. Most of the light comes from the big bright light on I-10. She added that perhaps they could get another pole installed on the right hand side coming from I-10.

Dr. Bautista said they would look at it and give them an update.

Agenda Item #15: Discussion and possible action on setting a date for the 2026 Business and Retention and Expansion program. (Deniece Odie)

Mrs. Odie said she had put this on the agenda so they could set a date for their mixer. She was thinking maybe April or May....

Dr. Bautista said the previous one last year was in March and July 9th. There were two last year.

Mrs. Allison said she thought it should be before the actual business boot camp. That way they could encourage some of the businesses to see if they would be interested in joining the boot camp. That way she could have time to prepare and get more attendees if possible.

Mrs. Odie said maybe set it for late April and Vickie will check all the dates for them.

Mr. Green said they will look toward the end of April and then narrow it down to a specific date.

No Action

Agenda Item #16: Discussion and possible action on setting a date for the Strategic Planning Workshop. (Lyndon Stamps)

Mr. Stamps said, if possible, they want to get the ball rolling. He suggested maybe 30 minutes prior to their next meeting, like 5:30 if that's a good time for the board. They won't get everything done in 30 minutes but at least get started.

Mr. Green asked Mrs. Odie if she would be able to make it at that time.

Mrs. Odie stated she could make it work.

Mr. Stamps again stated he knew they wouldn't get everything done, but they could get it started. They have a direction and know where they're headed with it. At that meeting they can set up for the next meeting.

Mr. Green said he thought that would be a good start and confirmed the next schedule meeting at 5:30.

Mr. Kosar stated it's for the strategic plan, don't say a regular meeting because people will think its 5:30.

Mr. Olson said they would post a special meeting, workshop as you know before it and then a regular agenda for your 6 o'clock

Mr. Green asked if they had to make a motion.

Mr. Olson said they did not.

Agenda Item #17: Project Managers Report. (Dr. Bautista)

Dr. Bautista directed the board to his report in their packet. He spoke of the ribbon cutting from the past weekend at Milk and Brew.

He then spoke of project he was working on.

- Nationwide Trailers are moving forward with their project.
- Ace Hardware is moving along with their project. They are working through permits.

- Quick Trip on 1489 and I-10 has a fence up now. They didn't want that to become a truck parking lot, so they had them to fence it in.
- Milk and Brew that he just mentioned.
- Mod Dentist has a CO but hasn't opened it to customers yet. It's a nice state of the art dental facility at 359 next to the Dominoes.

He added that the next four are essentially logistic distribution facilities.

- Triangle Business Park, that will be on the I-10 frontage just past Flying J.
- Falcon Business Warehouse is off 359, just past the Mana House.
- On 5th Street going towards the police department there's a smaller logistics distribution facility coming in.
- On the north side, business park development off Garvey Rd, which is on the city council agenda tonight.

Then we went over the potential projects.

- 10th Street there is a developer that owns property from 10th Street to 12th Street. There are several tracks there and he is looking to bring commercial development there.
- Next to that development on 10th Street, they want to bring manufacturing for heavy tarps for 18 wheelers.
- 12th Street there is a potential development and expansion of the road. They're still looking to develop their project. The road may not come, but they're still looking to go through the permit process. They want to come back and meet with the city and identify that they do want to develop that road and if here's an opportunity for the city to reevaluate.

The food truck park that they're continuously looking for the city.

The project that are currently going on they have in their strategic plan, the document that he put in there as well, indicates essentially just a mission vision and the planning steps that need to be taken and stakeholders doing a SWAT analysis, identifying and looking at the data to support the direction that they want this organization to go. What project they want to embark on and how the board contributes to the activities that staff are going to implement.

Mr. Richardson said that 1489 dead's into 90, then you cross the railroad track at Gassner then asked who owns it.

Dr. Bautista stated they were in discussion now to verify who it all belongs to.

Mr. Richardson asked if he ever went down that road.

Dr. Bautista replied yes.

Mr. Richardson stated it was embarrassing. He brought someone out to show some property and when he turned his car to go down there ... it's embarrassing.

Dr. Bautista said Garvey, Gassner, Kellner, all are on the outskirts, they are trying to get a handle on. No one knows who owns them, if they're ours how do we do something about it.

Mr. Richardson stated it was an eyesore.

Agenda Item #18: Future Agenda Items.

Mrs. Allison said this was for Mrs. Watts. When she was looking over the financials, she was trying to see if there's anyway, she could produce a report to include in their packet month to month; because it's hard to track and train and spot. You can see change in revenue and change in expenses; but if you can't see it month to month it's hard to deviate between the different packets. Is there a way she can incorporate a month to month financial so they can see what the expenses are and see the change.

Mrs. Watts replied yes and added that she would send her a couple of examples, and they would go over it.

Mrs. Allison agreed and stated that would work.

Mr. Richardson asked if they want something on the agenda, what is their window? He thinks that it's important that they're not giving you something at the last moment and expect to see it when we have our meeting.

Dr. Bautista stated in the policies and procedures he had indicated 10 days. Now it's three business days that we

Mr. Olson said three full business days, not the day that we post or the day we have the meeting. If there is an emergency still let us know but otherwise give the staff a little more time.

Dr. Bautista stated he forgot to mention that they were recognized by the Texas Economic Development Council for receiving an award for economic excellence. They'll see that noted in their packet. They also posted it on their LinkedIn, and we're one of 80 plus organizations that received this award.

Agenda Item #19: Executive Session

The Brookshire Economic Development Corporation will meet in a closed session pursuant to Title 5, Chapter 551, of the Texas Government Code for the purpose of: Economic Development Discussions under Section 551.087; Consultation with legal counsel under Section 551.071; Deliberations on real property under Section 551.072; and Deliberations on personnel under Section 551.074.

N/A

Agenda Item #20: Discussion & possible action on Executive session items if necessary.

N/A

Agenda item #21: Adjournment.

Motion was made to adjourn.

Director, Lyndon Stamps / Secretary / Treasurer, Michael Kosar

All For
Motion Carried

6:50 p.m.

President, Eric Green

Secretary/Treasurer, Michael Kosar

Prepared by Vickie Casto

**Brookshire
Economic Development
Corporation**

**Financials
March 2026**

**Prepared by:
Julie Watts**

City of Brookshire
 Revenue And Expense Report
 As of March 31, 2026

3/31/2026 12:04 PM

108 - City - Brookshire Economic Development	Current Month Expense/Rev	Year To Date Expense/Rev	Current Year Budget	Budget Balance Remaining	% Balance Remaining	Prior Year YTD Balance	Prior Year FY End Bal.
Revenue Summary							
-	98,776.70	1,050,494.32	4,258,845.21	3,208,350.89	75.33%	661,693.94	1,613,974.29
Revenue Totals	<u>98,776.70</u>	<u>1,050,494.32</u>	<u>4,258,845.21</u>	<u>3,208,350.89</u>	<u>75.33%</u>	<u>661,693.94</u>	<u>1,613,974.29</u>
Expense Summary							
000-Non-Departmental	11,786.53	96,112.97	2,892,760.00	2,796,647.03	96.68%	91,184.26	376,172.81
Expense Totals	<u>11,786.53</u>	<u>96,112.97</u>	<u>2,892,760.00</u>	<u>2,796,647.03</u>	<u>96.68%</u>	<u>91,184.26</u>	<u>376,172.81</u>
Revenues Over(Under) Expenditures	<u>86,990.17</u>	<u>954,381.35</u>	<u>1,366,085.21</u>	<u>411,703.86</u>	<u>83.97%</u>	<u>570,509.68</u>	<u>1,237,801.48</u>

City of Brookshire
 Revenue and Expense Report
 As of March 31, 2026

3/31/2026 12:04 PM

108 - City - Brookshire Economic D Department Revenue	Current Month Expense/Rev	Year To Date Expense/Rev	Current Year Budget	Budget Balance Remaining	% Balance Remaining	Prior Year YTD Balance	Prior Year FY End Bal.
<hr/>							
Sales Tax							
-43050 Sales Tax	98,776.70	1,013,027.59	1,248,558.00	235,530.41	18.86%	661,693.94	1,546,582.89
Total Sales Tax	<u>98,776.70</u>	<u>1,013,027.59</u>	<u>1,248,558.00</u>	<u>235,530.41</u>	<u>18.86%</u>	<u>661,693.94</u>	<u>1,546,582.89</u>
Interest							
-43640 Interest Earned	0.00	37,466.73	500.00	(36,966.73)	(7393.35%)	0.00	67,391.40
Total Interest	<u>0.00</u>	<u>37,466.73</u>	<u>500.00</u>	<u>(36,966.73)</u>	<u>(7393.35%)</u>	<u>0.00</u>	<u>67,391.40</u>
Reserves							
-43700 Previous Year Reserve Funds	0.00	0.00	622,362.00	622,362.00	100.00%	0.00	0.00
-43710 Prior Yr Unexpended Funds	0.00	0.00	2,387,425.21	2,387,425.21	100.00%	0.00	0.00
Total Reserves	<u>0.00</u>	<u>0.00</u>	<u>3,009,787.21</u>	<u>3,009,787.21</u>	<u>100.00%</u>	<u>0.00</u>	<u>0.00</u>
Total	<u>98,776.70</u>	<u>1,050,494.32</u>	<u>4,258,845.21</u>	<u>3,208,350.89</u>	<u>75.33%</u>	<u>661,693.94</u>	<u>1,613,974.29</u>
Total Revenue	<u>98,776.70</u>	<u>1,050,494.32</u>	<u>4,258,845.21</u>	<u>3,208,350.89</u>	<u>75.33%</u>	<u>661,693.94</u>	<u>1,613,974.29</u>

City of Brookshire
 Revenue and Expense Report
 As of March 31, 2026

108 - City - Brookshire Economic D Department Expense	Current Month Expense/Rev	Year To Date Expense/Rev	Current Year Budget	Budget Balance Remaining	% Balance Remaining	Prior Year YTD Balance	Prior Year FY End Bal.
000-Non-Departmental							
<u>Personnel</u>							
000-51000 Salaries	6,250.63	42,872.58	75,937.00	33,064.42	43.54%	8,188.50	47,634.91
000-51130 Retirement Contributions	970.72	10,074.45	11,618.00	1,543.55	13.29%	1,271.67	7,397.69
Total Personnel	<u>7,221.35</u>	<u>52,947.03</u>	<u>87,555.00</u>	<u>34,607.97</u>	<u>39.53%</u>	<u>9,460.17</u>	<u>55,032.60</u>
<u>Taxes</u>							
000-51100 Payroll Taxes	478.16	3,279.72	5,809.00	2,529.28	43.54%	626.43	3,644.12
Total Taxes	<u>478.16</u>	<u>3,279.72</u>	<u>5,809.00</u>	<u>2,529.28</u>	<u>43.54%</u>	<u>626.43</u>	<u>3,644.12</u>
<u>Insurance</u>							
000-51140 Health Insurance	985.70	5,813.69	10,996.00	5,182.31	47.13%	1,191.38	7,083.14
Total Insurance	<u>985.70</u>	<u>5,813.69</u>	<u>10,996.00</u>	<u>5,182.31</u>	<u>47.13%</u>	<u>1,191.38</u>	<u>7,083.14</u>
<u>Not Categorized</u>							
000-51540 Health Insurance	1.34	8.04	0.00	(8.04)	0.00%	1.34	9.38
000-52000 Legal Fees	1,537.00	4,967.50	15,000.00	10,032.50	66.88%	3,687.00	11,489.50
000-52030 Professional Services	0.00	5,115.00	48,000.00	42,885.00	89.34%	24,305.00	73,912.18
000-52031 Bedc Coordinator	0.00	0.00	70,000.00	70,000.00	100.00%	0.00	109,800.00
000-52034 Engineer Services	0.00	0.00	25,000.00	25,000.00	100.00%	0.00	0.00
000-53010 Office Supplies	0.00	1,668.79	3,000.00	1,331.21	44.37%	12.34	1,843.40
000-53110 Membership & Dues	0.00	4,800.00	6,000.00	1,200.00	20.00%	0.00	0.00
000-54000 Building Maintenance	0.00	0.00	20,000.00	20,000.00	100.00%	2,599.99	2,599.99
000-54010 Equipment Maintenance	0.00	0.00	1,000.00	1,000.00	100.00%	0.00	336.98
000-54190 Public Mowing	0.00	0.00	20,000.00	20,000.00	100.00%	15,613.39	34,813.39
000-55030 Legal Notices	0.00	0.00	1,000.00	1,000.00	100.00%	0.00	0.00
000-55050 Travel & Training	0.00	584.47	20,000.00	19,415.53	97.08%	926.50	2,101.10

City of Brookshire
 Revenue and Expense Report
 As of March 31, 2026

3/31/2026 12:04 PM

108 - City - Brookshire Economic D Department Expense	Current Month Expense/Rev	Year To Date Expense/Rev	Current Year Budget	Budget Balance Remaining	% Balance Remaining	Prior Year YTD Balance	Prior Year FY End Bal.
000-55070 Bank Charges	0.00	0.00	500.00	500.00	100.00%	0.00	0.00
000-55090 Telephone	0.00	0.00	500.00	500.00	100.00%	0.00	283.85
000-55120 Advertising	0.00	932.60	10,000.00	9,067.40	90.67%	0.00	0.00
000-56140 Beautification	0.00	0.00	25,000.00	25,000.00	100.00%	2,990.00	2,990.00
000-56150 City Parks Project Equipment Maintenance	0.00	0.00	100,000.00	100,000.00	100.00%	8,600.00	20,938.77
000-56160 GIS	0.00	0.00	5,000.00	5,000.00	100.00%	0.00	0.00
000-56170 Facilities/Infrastructure Proj	0.00	0.00	515,000.00	515,000.00	100.00%	0.00	0.00
000-56200 Business Improvement Grant	0.00	0.00	100,000.00	100,000.00	100.00%	0.00	0.00
000-56220 Downtown Improvements	0.00	0.00	253,000.00	253,000.00	100.00%	9,590.00	9,590.00
000-56990 Emergency Management	0.00	0.00	20,000.00	20,000.00	100.00%	0.00	0.00
000-57000 Technology	0.00	12,870.17	25,000.00	12,129.83	48.52%	11,580.72	39,704.41
000-57010 Computer & Software	1,562.98	3,125.96	3,000.00	(125.96)	(4.20%)	0.00	0.00
000-57030 Capital Outlay- Equipment	0.00	0.00	10,000.00	10,000.00	100.00%	0.00	0.00
000-57040 Capital Outlay- Computers	0.00	0.00	10,000.00	10,000.00	100.00%	0.00	0.00
000-57070 Capital Outlay- Special Equipment	0.00	0.00	5,000.00	5,000.00	100.00%	0.00	0.00
000-57100 Capital Outlay- Facilites	0.00	0.00	82,400.00	82,400.00	100.00%	0.00	0.00
000-57350 Grant Matching	0.00	0.00	103,000.00	103,000.00	100.00%	0.00	0.00
000-57410 Real Estate	0.00	0.00	1,030,000.00	1,030,000.00	100.00%	0.00	0.00
000-57450 Type B Projects	0.00	0.00	262,000.00	262,000.00	100.00%	0.00	0.00
Total Not Categorized	<u>3,101.32</u>	<u>34,072.53</u>	<u>2,788,400.00</u>	<u>2,754,327.47</u>	<u>98.78%</u>	<u>79,906.28</u>	<u>310,412.95</u>
Total Non-Departmental	<u>11,786.53</u>	<u>96,112.97</u>	<u>2,892,760.00</u>	<u>2,796,647.03</u>	<u>96.68%</u>	<u>91,184.26</u>	<u>376,172.81</u>
	11,786.53	96,112.97	2,892,760.00	2,796,647.03	96.68%	91,184.26	376,172.81

City of Brookshire
 Revenue and Expense Report
 As of March 31, 2026

3/31/2026 12:04 PM

108 - City - Brookshire Economic D Department Expense	Current Month Expense/Rev	Year To Date Expense/Rev	Current Year Budget	Budget Balance Remaining	% Balance Remaining	Prior Year YTD Balance	Prior Year FY End Bal.
Total Expense							

EDC - CHECKING -



Account Information

Balance

Previous Day Transactions (-\$1,537.00 / +\$1,537.00)	\$0.00
Current Balance	\$25,000.00
Total Float	\$0.00
Holds	\$0.00
Pending Transactions (-\$0.00 / +\$0.00)	\$0.00
Other Transfers	\$0.00
Today's Float	\$0.00
Available Balance	\$25,000.00
Line Of Credit	\$0.00
Sweep Account EDC - ICS 99794081	\$3,406,930.15
Total Funds Available	\$3,431,930.15

Activity

Last Deposit (Mar 30, 2026)	\$1,537.00
Last Check (Mar 30, 2026)	\$1,537.00
Last Overdrawn	Mar 29, 2024

Interest

Last Interest Payment	\$35.96
-----------------------	---------

Account Information**Balance**

Previous Day Transactions (-\$1,537.00 / +\$0.00)	-1,537.00
Current Balance	\$3,406,930.15
Total Float	\$0.00
Holds	\$0.00
Pending Transactions (-\$0.00 / +\$0.00)	\$0.00
Other Transfers	\$0.00
Today's Float	\$0.00
Available Balance	\$3,406,930.15
Line Of Credit	\$0.00
Total Funds Available	\$3,406,930.15

Activity

Last Deposit (Feb 02, 2026)	\$209,558.50
Last Check (Mar 30, 2026)	\$1,537.00

Interest

Current Accrued Interest	\$7,441.33
Last Interest Payment (Jan 09, 2024)	\$0.00
Interest Paid 2026	\$14,249.58
Interest Paid 2025	\$73,708.40



VICKIE CASTO
Account Number: XXXX XXXX XXXX 9996

Billing Questions:
800-367-7576

Website:
www.cardaccount.net

Send Billing Inquiries To:
Card Service Center, PO Box 569120, Dallas, TX 75356

RECEIVED
3/23/26
[Handwritten Signature]

NEWFIRST NATIONAL BANK Credit Card Account Statement
March 15, 2026

SUMMARY OF ACCOUNT ACTIVITY

Previous Balance	\$0.00
- Payments	\$0.00
- Other Credits	\$0.00
+ Purchases	\$0.00
+ Cash Advances	\$0.00
+ Fees Charged	\$0.00
+ Interest Charged	\$0.00
= New Balance	\$0.00

PAYMENT INFORMATION

New Balance:	\$0.00
Minimum Payment Due:	\$0.00
Payment Due Date:	April 9, 2026

Account Number XXXX XXXX XXXX 9996
Credit Limit \$2,500.00
Available Credit \$2,475.00
Statement Closing Date March 15, 2026
Days in Billing Cycle 0

MESSAGES

PROTECT YOURSELF FROM SCAMMERS!

We will never call, text, or email and ask you for your personal information. Some scammers will call and pretend to be from the Card Service Center. We will never call or text you and ask for sensitive information such as account or card number information, passwords or user names, or social security numbers. Please DO NOT give out that information.

If you feel pressured or concerned about a phone call, please hang up and call us at 800-367-7576 (the phone number located on the back of your credit card). Our Card Service Center team is always glad to check and can verify the information.

Please see reverse side of page 1 for important information.

5762 0001 BHH 001 7 9 260315 0

PAGE 1 of 2

15 1127 7010 V85 01AB5762

332

NEWFIRST NATIONAL BANK
1550 N BROWN RD 150
LAWRENCEVILLE GA 30043



Account Number: XXXX XXXX XXXX 9996
New Balance: \$0.00
Minimum Payment Due: \$0.00
Payment Due Date: April 9, 2026

Please use enclosed envelope to remit payment.

Amount Enclosed: \$

Indicate name or address change on reverse side and check here.

Make Check Payable to:

CARD SERVICE CENTER
PO BOX 569100
DALLAS TX 75356-9100

VICKIE CASTO
CITY BROOKSHIRE EDC 332
PO BOX 160
BROOKSHIRE TX 77423-0160

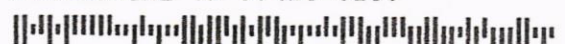
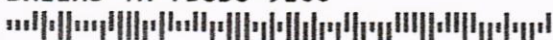

55906170107699960000000000000009

1-2



VICKIE CASTO
Account Number: XXXX XXXX XXXX 9996

TRANSACTIONS

An amount followed by a minus sign (-) is a credit unless otherwise indicated.

Tran Date	Post Date	Reference Number	Transaction Description	Amount
02/14	02/15	7541823DX799NAPY5	IONOS INC CHESTERBROOK PA	\$25.54
02/19	02/20	0541019E2326QZ12A	QUILL CORPORATION COLUMBIA SC	\$178.60
02/19	02/20	0541019E2326QZ122	QUILL CORPORATION COLUMBIA SC	\$265.83
02/21	02/22	5543286E560F77VMP	MICHAELS STORES 1363 KATY TX	\$12.98
02/25	02/27	0230537E95SBRS17M	HOBBY-LOBBY #0093 KATY TX	\$37.97
02/28	03/02	5543286EB62K50DN5	SQ *KOLACHE BOSS & DON BROOKSHIRE TX	\$55.96
03/04	03/05	7541823EF7APF79SV	IONOS INC CHESTERBROOK PA	\$36.95
03/07	03/08	0541019EK326QV1R0	QUILL CORPORATION COLUMBIA SC	\$490.36
03/14	03/15	7541823ET7BEDV9KP	IONOS INC CHESTERBROOK PA	\$25.54
03/15	03/15	000000000000COMPC	TOTAL PURCHASES \$1,129.73	
			TOTAL \$1,129.73	

INTEREST CHARGE CALCULATION

Your Annual Percentage Rate (APR) is the annual interest rate on your account

Type of Balance	Annual Percentage Rate (APR)	Balance Subject to Interest Rate	Days in Billing Cycle	Interest Charge
Purchases	17.74% (v)	\$0.00	0	\$0.00
Cash Advances	17.74% (v)	\$0.00	0	\$0.00

(v) - variable

To avoid additional interest charges, pay your New Balance in full on or before the Payment Due Date.

Exciting news! Go online today and check out the all-new enhancements to the Card Service Center website. E-statements, additional payment options, links to Preferred Points website, and other helpful sites. Visit us today at www.cardaccount.net to enroll your credit card account(s) on the newly enhanced website.

Thank you for the opportunity to serve your credit card needs. Should your future plans include travel, please contact us at 1-800-367-7576.

1-2

BHH

2-28-2026 Mik + Brew
Ribbon Cutting
Kolache Boss & Donuts

4327 S Front St
Brookshire, TX 77423
(281) 934-4200

Feb 28, 2026
9:08 AM
Yunanh

Ticket: \$55.96 Payment
Receipt: dusk
Authorization: 02838C

Mastercard
AID A0 00 00 00 04 10 10

MIXED DONUTS x 4 \$55.96
(\$13.99 each)
DOZEN

Total \$55.96
Mastercard 9996 \$55.96
(Contactless)

Michaels

MICHAEL'S STORE #1363 (832) 957-9900
STORE MANAGER KARA P.
2838 Grand Pkwy
Katy, TX 77449-1998

8 9741 0895 6919 2151 1111 4164 1254 5292



100 CALL 801 1363954 02/21/26 14:29

ITEM INFORMATION

Order NO: 2635712239/10191

Price: 13.99 Qty: 4 00195158135633

Reg 11.99 LO @ 11.99 11.99

YOU SAVED .00

PURCHASE SUMMARY

SUBTOTAL 11.99
SALES TAX 8.25% .99
TOTAL 12.98

ACCOUNT NUMBER *** 9996

MasterCard 12.98

APPROVAL: 02120C CHIP ONLINE

Application label: Mastercard

AID: A000000041010

TVR: 000008000

TSI: EB00

This receipt expires at 60 days on 04/22/26

Click Buy Create Shop on Michaels.com today!

Get Savings & Inspiration! Text SIGNUP to 773283

To Sign Up for Email & Text Messages

*Msg & Data Rates May Apply

You will receive 1 automated message

with a link to join Michaels alerts.

New? Bring! Apply at michaels.com/jobs

THANK YOU FOR SHOPPING AT MICHAEL'S

Effective 11/22/2022 Clearance sales are considered

final, sold AS IS and are not

returnable for a refund or exchange.

Dear Valued Customer:

Michaels return and coupon policies are available
at michaels.com and in-store at registers.

02/21/26 14:29

Mik + Brew
Ribbon for Ribbon Cutting 2-28-2026

HOBBY LOBBY

Super Savings, Super Selection!

1787 Fry Road

Katy, TX 77449
(281) 578-7750

S-93 R-6 T-4003 WADIA P SALE

10150000 Frames 11.99 YFN
10150000 Frames 25.98 YFN
2 @ 12.99 each

SUBTOTAL 37.97
TAX TOTAL 0.00
TOTAL 37.97

M/C ACCOUNT #: *****9996 37.97

AUTH#: 02502C
ACCT: MASTERCARD
INSERTED

CARD # *****9996
MasterCard
EXP **/**

REF # 170702251042 02502C
RESP 00 ISO 00

AID: A0000000041010
TST: E800 APC: CUR: 0840

TVR: 000008000
APP: MasterCard
IAD: 0110A040032200000000000000000000

CHANGE DUE 0.00

TAX EXEMPT CUSTOMER

Number of Items Purchased: 3

THANK YOU

PLEASE COME AGAIN

Visit our website at www.hobbylobby.com



02/25/26 04:56 PM

RETURN POLICY

Hobby Lobby values customer satisfaction,
with or without the receipt.

WITH ORIGINAL SALES RECEIPT:

Within 90 days of purchase, we will gladly exchange the

merchandise, give a store credit, or issue a refund based on the

original method of payment. There will be a wait of 10 calendar

days on stock purchases, or merchandise credit can be issued.

WITHOUT ORIGINAL SALES RECEIPT:

You may exchange the merchandise or be issued a merchandise

credit based on the lowest selling price in the last 60 days.

Valid ID is required.

*Returns or exchanges of certain Machines and Sewing Machines

(except Singer Stitch Quick) are prohibited unless customer presents

original receipt and products are in new/unopened condition.

Warranty claims must be submitted directly to manufacturer.

We reserve the right to limit or refuse to accept the return of certain

products and non-recipied items.

3-Certificate Frame
 Milk + Brew - Vaegus, N.Y. - Maderitos Sweet + Sour



108-000-32033

Technology



IONOS Inc.

Two Logan Square, 100 N 18th St., Suite 400
Philadelphia, PA 19103
USA

Two Logan Square, 100 N 18th St. · Suite 400
Philadelphia, PA 19103 · USA

Vickie Casto
Brookshire EDC
4029 Fifth St
Brookshire, TX 77423-8793
UNITED STATES

Invoice: 202060838344
Invoice Date: 03/13/2026
Customer ID: 447408986
Contract ID: 103888979

Help Center: ionos.com/help
My IONOS: my.ionos.com/invoices

Your IONOS Personal Consultant:

Ainoa S

+1 267 366 6056

Invoice

Billing period starting: 03/12/2026

Item	Service	Charges	Usage	Taxable Portion	Total
Contract: 103888979 - IONOS HiDrive Pro					
1	Basic Fee 03/12/2026-04/11/2026	\$20.00 a month	1 mo.	\$16.00	\$20.00
Net Total					\$20.00
Net (non-taxable portion)					\$4.00
Net (taxable portion)					\$16.00
Tax					\$1.28
Total amount due					\$21.28

Please **DO NOT** send cash, check or money order

The total amount due will be charged to your credit card within the next seven days, most likely in the next day or two. Thank you.

Do you have questions regarding this invoice?

Please refer to your [Help Center](https://ionos.com/help) or log in to my.ionos.com for further information.

108-000-52033

Technology



IONOS Inc.

Two Logan Square, 100 N 18th St., Suite 400
Philadelphia, PA 19103
USA

Two Logan Square, 100 N 18th St. · Suite 400
Philadelphia, PA 19103 · USA
Vickie Casto
Brookshire EDC
4029 Fifth St
Brookshire, TX 77423-8793
UNITED STATES

Invoice: 202060838337
Invoice Date: 03/13/2026
Customer ID: 447408986
Contract ID: 103888962

Help Center: ionos.com/help
My IONOS: my.ionos.com/invoices

Your IONOS Personal Consultant:

Ainoa S

+1 267 366 6056

Invoice

Billing period starting: 03/12/2026

Item	Service	Charges	Usage	Taxable Portion	Total
Contract: 103888962 - IONOS HiDrive Basic					
Basic fee (\$1.50)					
1	Basic Fee 03/12/2026-04/11/2026	\$1.50 a month	1 mo.	\$1.20	\$1.50
Additional services (\$2.50)					
2	IONOS HiDrive Office 03/12/2026-04/11/2026	\$2.50 a month	1 mo.	\$2.00	\$2.50
Net Total					\$4.00
Net (non-taxable portion)					\$0.80
Net (taxable portion)					\$3.20
Tax					\$0.26
Total amount due					\$4.26
Please DO NOT send cash, check or money order					

The total amount due will be charged to your credit card within the next seven days, most likely in the next day or two. Thank you.

Do you have questions regarding this invoice?

Please refer to your [Help Center](https://ionos.com/help) or log in to my.ionos.com for further information.



Office Supplies

108-000-52010

What are you looking for today?

Rec'd 2-18-2024



✔ Your order has been submitted.

Order information

Account #: 10451670
 Recap number: 117486736
 Order date: 02/17/2026 10:48 AM EST
 Contact information: edc@brookshiretx.gov

Delivery information

BROOKSHIRE EDC
 BROOKSHIRE EDC
 4029 FIFTH ST
 BROOKSHIRE, TX 77493

Payment information

Payment Method: Mastercard **** 9996
 Card holder name: Vickie Casto
 4029 Fifth St
 Brookshire, TX 77493

Congratulations, you have 409 points for future rewards!

Delivery Tomorrow, Feb 18 (1 item)

Item Details

Price	Total
\$164.99	\$164.99

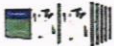

Hammermill Premium 8.5" x 11" Laser Paper, 24 lbs., 98 Brightness, 5000 Sheets/Carton (104604)
 Item # 901-104604CT
 1 (Carton)

* As soon as we process your order you will receive an email order confirmation that contains your final delivery details.
 * To ensure you receive your final order confirmation and order status updates, please add confirmation@Quill.com and info@Quill.com to your trusted sender list.

Order summary

Merchandise total: \$164.99
[Shipping:](#) Free

[Handling:](#)

Free

[Estimated tax:](#)

\$13.61

Total:

\$178.60

Points summary

[View points history](#)

Saved points

245

Earned on this order

164

Redeemed on this order

0

Available balance

409

Delivering quality & savings with our in-house brands

 Staples



UNION & SCALE™

PICK
MeUP
PROVISIONS

COASTWIDE
PROFESSIONAL

workplace2.0

perk

Staples TECH



Office Supplies 100-000 0000



What are you looking for today?

Received 2-18-2024

\$ 265.83



✔ Your order has been submitted.

Order information

Recap number:

117462683

Order date:

02/13/2026 10:31 AM EST

Contact information:

edc@brookshiretx.gov

Delivery information

Brookshire EDC
Brookshire Edc
4029 Fifth St
Brookshire, TX 77493

Payment information

Payment Method: Mastercard **** 9996

Card holder name: Vickie Casto

4029 Fifth St
Brookshire, TX 77493

Congratulations, you have 245 points for future rewards!

Delivery Mon, Feb 16 - Tue, Feb 17 (2 items)

Item Details

Price	Total
\$11.59	\$11.59



Quill Brand® Electronics Duster, 10 oz. Spray Can (Q10521)
Item # 901-712196
1 (Each)

\$116.99	\$233.98
----------	----------



HP 414A Black Standard Yield Toner Cartridge, Prints Up to 2,400 Pages (W2020A)
Item # 901-24398984
2 (Each)

* As soon as we process your order you will receive an email order confirmation that contains your final delivery details.

*To ensure you receive your final order confirmation and order status updates, please add confirmation@Quill.com and info@Quill.com to your trusted sender list.

Order summary

Merchandise total:	\$245.57
Shipping:	Free
Handling:	Free
Estimated tax:	\$20.26

Total: **\$265.83**

Points summary

[View points history](#)

Saved points	0
Earned on this order	245
Redeemed on this order	0

Available balance 245

Delivering quality & savings with our in-house brands



108-000-52033

Technology



IONOS Inc.

Two Logan Square, 100 N 18th St., Suite 400
Philadelphia, PA 19103
USA

Two Logan Square, 100 N 18th St. · Suite 400
Philadelphia, PA 19103 · USA

Vickie Casto
Brookshire EDC
4029 Fifth St
Brookshire, TX 77423-8793
UNITED STATES

Invoice: 202060621442
Invoice Date: 03/03/2026
Customer ID: 447408986
Contract ID: 54615938

Help Center: ionos.com/help
My IONOS: my.ionos.com/invoices

Your IONOS Personal Consultant:

Ainoa S

+1 267 366 6056

Invoice

Billing period starting: 03/02/2026

Item	Service	Charges	Usage	Taxable Portion	Total
Contract: 54615938 - IONOS Premium					
1	IONOS SiteAnalytics Plus 02/12/2026-05/11/2026	\$4.99 a month	3 mo.	\$11.98	\$14.97
2	IONOS PHP 5.4 Extended Support 02/08/2026-03/07/2026	\$19.76 a month	1 mo.	\$15.81	\$19.76
Net Total					\$34.73
Net (non-taxable portion)					\$6.94
Net (taxable portion)					\$27.79
Tax					\$2.22
Total amount due					\$36.95
Please DO NOT send cash, check or money order					

The total amount due will be charged to your credit card within the next seven days, most likely in the next day or two. Thank you.

Do you have questions regarding this invoice?
Please refer to your [Help Center](https://ionos.com/help) or log in to my.ionos.com for further information.

108-000-53010

Office Supplies

Credit Card Purchase Receipt



PO Box 37600
Philadelphia, PA 19101-0600

Order Date: 03/03/2026
Ship Date: 03/05/2026
Invoice Date: 03/05/2026
TIN: 04-2896127

Sold To:

Brookshire Edc
Brookshire Edc
4029 Fifth St
Brookshire TX 77423-0001

Ship To:
Brookshire Edc
Brookshire Edc
4029 Fifth St
Brookshire TX 77423

Customer PO: edcbrookshire Order #: 189708894 Invoice #: 48036461 Account #: 10451670

Item Number	Description	Color	Qty Shipped	Price	Unit	Extended
901-24596190	3-COLOR TONER SET		1	\$452.99	pack	\$452.99



Always happy to help



800.982.3400



invoice@quill.com

Check the status of this order and track delivery at [Quill.com/my account](https://www.quill.com/my-account).

Merchandise Amt \$452.99
Tax: \$37.37
Shipping: Free

**This amount has been charged
to your credit card: \$490.36**



THIS IS A RECEIPT FOR YOUR CREDIT CARD PURCHASE

Pending settlement from your financial institution.

108-000-52033

Technology



IONOS Inc.

Two Logan Square, 100 N 18th St., Suite 400
Philadelphia, PA 19103
USA

Two Logan Square, 100 N 18th St. · Suite 400
Philadelphia, PA 19103 · USA

Vickie Casto
Brookshire EDC
4029 Fifth St
Brookshire, TX 77423-8793
UNITED STATES

Invoice: 202060204372
Invoice Date: 02/13/2026
Customer ID: 447408986
Contract ID: 103888962

Help Center: ionos.com/help
My IONOS: my.ionos.com/invoices

Your IONOS Personal Consultant:

Ainoa S

+1 267 366 6056

Invoice

Billing period starting: 02/12/2026

Item	Service	Charges	Usage	Taxable Portion	Total
Contract: 103888962 - IONOS HiDrive Basic					
Basic fee (\$1.50)					
1	Basic Fee 02/12/2026-03/11/2026	\$1.50 a month	1 mo.	\$1.20	\$1.50
Additional services (\$2.50)					
2	IONOS HiDrive Office 02/12/2026-03/11/2026	\$2.50 a month	1 mo.	\$2.00	\$2.50
Net Total					\$4.00
Net (non-taxable portion)					\$0.80
Net (taxable portion)					\$3.20
Tax					\$0.26
Total amount due					\$4.26
Please DO NOT send cash, check or money order					

The total amount due will be charged to your credit card within the next seven days, most likely in the next day or two. Thank you.

Do you have questions regarding this invoice?
Please refer to your [Help Center](https://ionos.com/help) or log in to my.ionos.com for further information.

108-000-52033
Technology



IONOS Inc.

Two Logan Square, 100 N 18th St., Suite 400
Philadelphia, PA 19103
USA

Two Logan Square, 100 N 18th St. · Suite 400
Philadelphia, PA 19103 · USA
Vickie Casto
Brookshire EDC
4029 Fifth St
Brookshire, TX 77423-8793
UNITED STATES

Invoice: 202060204376
Invoice Date: 02/13/2026
Customer ID: 447408986
Contract ID: 103888979

Help Center: ionos.com/help
My IONOS: my.ionos.com/invoices

Your IONOS Personal Consultant:

Ainoa S

 +1 267 366 6056

Invoice

Billing period starting: 02/12/2026

Item	Service	Charges	Usage	Taxable Portion	Total
Contract: 103888979 - IONOS HiDrive Pro					
1	Basic Fee 02/12/2026-03/11/2026	\$20.00 a month	1 mo.	\$16.00	\$20.00
Net Total					\$20.00
Net (non-taxable portion)					\$4.00
Net (taxable portion)					\$16.00
Tax					\$1.28
Total amount due					\$21.28
Please DO NOT send cash, check or money order					

The total amount due will be charged to your credit card within the next seven days, most likely in the next day or two. Thank you.

Do you have questions regarding this invoice?

Please refer to your [Help Center](https://ionos.com/help) or log in to my.ionos.com for further information.



PREFERRED FACILITIES GROUP - USA

February 19, 2026

Mailing Address:
PO Box 20658
Beaumont, TX 77720-0658

Ramiro Bautista
City of Brookshire
4029 5th St
Brookshire, TX 77423

{409} 842-8293
{409} 842-2274
pfg@pfg-usa.com
pfg-usa.com

Project: "Brookshire Hovas Park Concrete"

Subject: "Proposal"

Job Order Contracting

Dear Mr. Bautista,

Co-Op Purchasing Agreements

We are pleased to submit our proposal utilizing our 728-24 Buy Board Texas Contract based on local CCI and coefficient of .89.

Indefinite Delivery, Indefinite Quantity - IDIQ

Proposal Recap:

Multiple Award Construction Contracts - MACC

- **Furnish material and Labor** to Finish grade, form, and pour roughly 17,00 sqft of 4" concrete with 3/8 rebar every 16" O.C. and sloped towards basins
- **Furnish material and Labor** to install (3) catch basins. (1) located in each of the (3) zones
- **Furnish material and Labor** to form and pour (3) retaining walls running along the inside perimeter of the backstops. 4' high and 6" thick with #4 rebar every 12" O.C. a perimeter beam 12x24 will be poured to prevent the walls from falling or cracking. The corners will be smoothed and rounded to prevent injury.
- Clean up and haul off all construction related debris associated with this project.

Task Order Contracts TOC

Construction Management - Agent or At-Risk

Design Build

Proposal Cost	\$ 191,064.88
Bond (If Applicable)	\$ 0.00
Total Cost	\$ 191,064.88

Government

We estimate approximately **Thirty (30)** working days to complete. We explicitly exclude all liquidated damages for this project due to market volatility and supply chain challenges.

Commercial

Education

Our estimate is based on our interpretation of the project as presented to us. Our scope is limited to the line items broken down into individual tasks of work and developed based upon the Unit Price Book rate as modified by the city cost adjustment and our Coefficient. All pricing for the required line-item estimate is derived from the current calendar year RSMMeans Facilities Construction Cost Data Book with Updates.

Industrial

Infrastructure

Communications

Corporate/Retail

Once the quantities of work and price are approved, the individual Job Order becomes a fixed-price lump sum contract.

Assembly

Southeast Texas

Deep East Texas

Central Texas

Texas Gulf Coast





PREFERRED FACILITIES GROUP - USA

Mailing Address:
PO Box 20658
Beaumont, TX 77720-
0658

(409) 842-8293
(409) 842-2274
pfg@pfg-usa.com
pfg-usa.com

This pricing is based on initiating the project on Friday morning, with the demolition expected to be completed by Sunday night. Given the drying times associated with plaster repairs and painting, it is anticipated that these tasks will be conducted during standard courthouse hours. Please do not hesitate to contact us at 409-842-8293 at your earliest convenience to discuss this estimate in further detail.

Respectfully submitted,
Preferred Facilities Group - USA

Job Order Contracting

Joshua Schmuck
Project Manager/Estimator

Co-Op Purchasing
Agreements

cc: PFG/file
26-0001

Indefinite Delivery,
Indefinite Quantity - IDIQ

Multiple Award
Construction Contracts -
MACC

Task Order Contracts
TOC

Construction
Management - Agent or
At-Risk

Design Build

Government

Commercial

Education

Industrial

Infrastructure

Communications

Corporate/Retail

Assembly

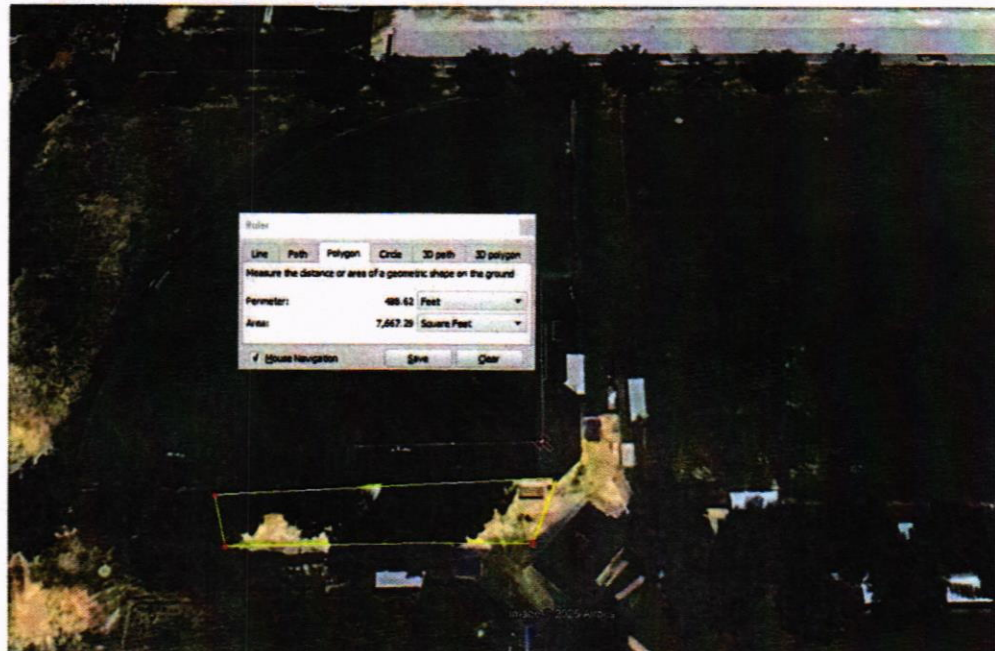

Southeast Texas

Deep East Texas

Central Texas

Texas Gulf Coast





PREFERRED FACILITIES GROUP - USA

Mailing Address:
PO Box 20658
Beaumont, TX 77720-0658

(409) 842-8293
(409) 842-2274
pfg@pfg-usa.com
pfg-usa.com

Job Order Contracting

Co-Op Purchasing Agreements

Indefinite Delivery, Indefinite Quantity - IDIQ

Multiple Award Construction Contracts - MACC

Task Order Contracts TOC

Construction Management - Agent or At-Risk

Design Build

Government

Commercial

Education

Industrial

Infrastructure

Communications

Corporate/Retail

Assembly

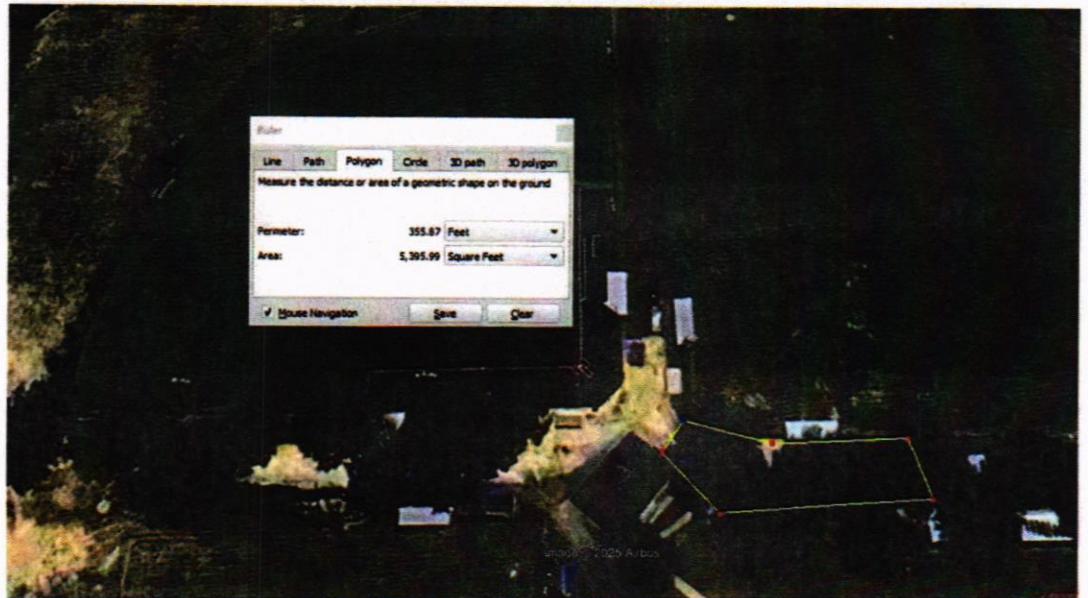

Southeast Texas

Deep East Texas

Central Texas

Texas Gulf Coast





Select Generators

21925 Franz Road | #402 | Katy, Texas 77449
(281) 394-4041 | office@selectgenerators.com |
www.selectgenerators.com

RECIPIENT:

Brookshire Amphitheater

4022 5th Street
Brookshire, Texas 77423
Phone: 2816650598 Ramiro Bautista

Quote #76715

Sent on Feb 25, 2026

Total \$34,823.46

Product/Service	Description	Qty.	Unit Price	Total
Install	Install four (4) 30-foot light poles, each equipped with one fixture. Provide and pour concrete bases for each pole. Install 450 linear feet of underground electrical, including a dedicated 20-amp, 240-volt circuit.	1	\$34,823.46	\$34,823.46

Total \$34,823.46

Quote Terms & Disclaimer - Select Generators

- The following are not included in this quote and may result in additional charges if required:
 - Gas meter upgrades
 - Second gas meter installation
 - New gas service (if not currently available)
 - Wi-Fi extenders
 - Any repairs related to utilities
 - Repairs to unmarked underground lines (e.g., irrigation, well/septic lines)

Select Generators will contact TX 811 before any excavation to locate utility lines.

• Pilot Light Relighting: We may attempt to relight your water heater's pilot light as a courtesy. If we are unable to due to a dirty pilot tube, faulty thermocouple, the unit's age, or any other issues, Select Generators is not responsible for the repair. If needed, we can coordinate a technician to resolve the issue; pricing will vary depending on the cause.

- Labor for residential property improvements is not subject to sales tax.
- A surcharge applies to all credit card payments.

Signature: _____ **Date:** _____

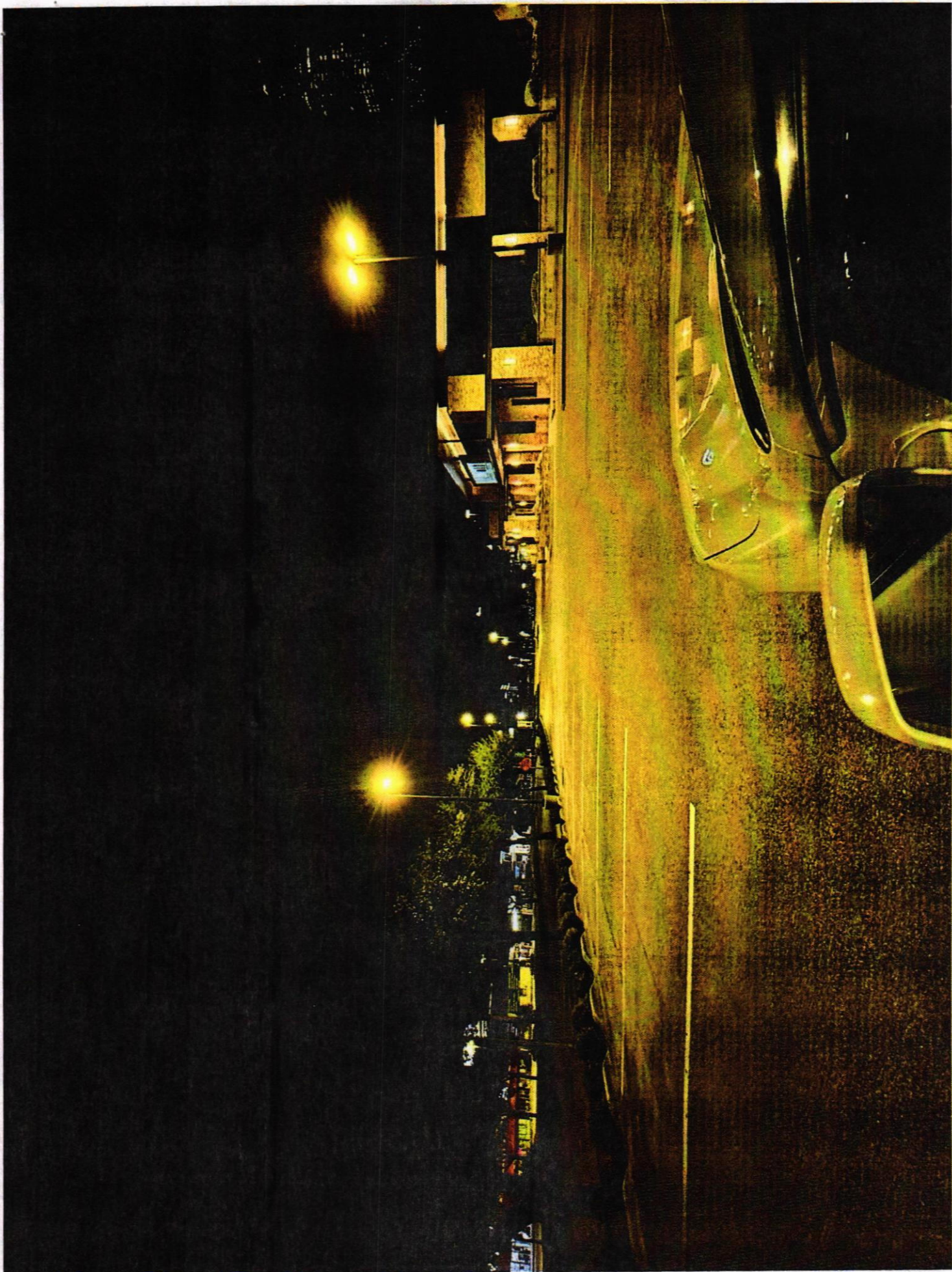

The logo for KL00 SOLUTIONS features the word "KL00" in a large, bold, red font with a white outline. Below it, the word "SOLUTIONS" is written in a smaller, blue, sans-serif font. To the left of "SOLUTIONS" are three horizontal blue lines. The background of the entire advertisement is a dark, atmospheric photograph of an industrial facility at night, with several tall, black streetlights illuminating the scene. The sky is dark with some light streaks, and the ground is dark and reflective.

KL00
SOLUTIONS

**HIGH-PERFORMANCE
LED AREA LIGHT**

Outdoor Lighting Solutions

POWERFUL, EFFICIENT AND VERSATILE LED LIGHTING SOLUTION

Arcadia's ALC Area Light family is designed to replace large and power-consuming MH fixtures with high-quality lighting while managing budget. The ALC family is versatile: a variety of mounting bracket options, support for light control, motion sensors, Bluetooth sensors, a variety of optical systems, providing reliable and excellent lighting solutions for any kind of renovation project or new project.

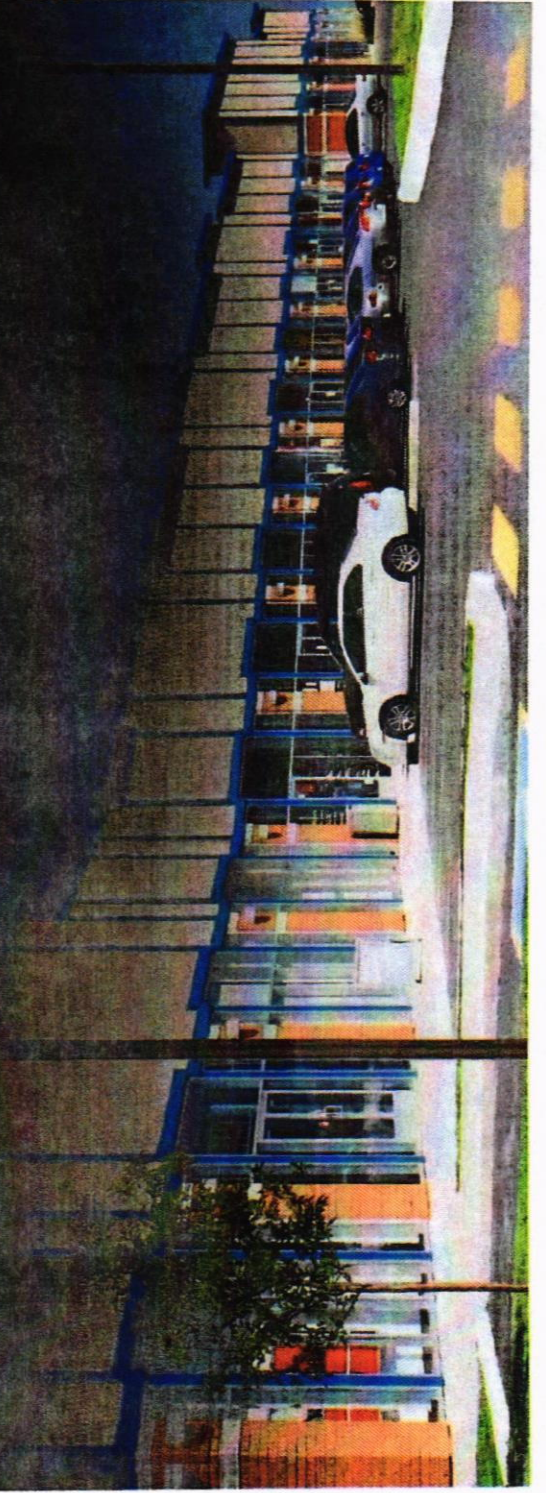

SUPERIOR PERFORMANCE, ENERGY AND MAINTENANCE SAVINGS, EASY INSTALLATION

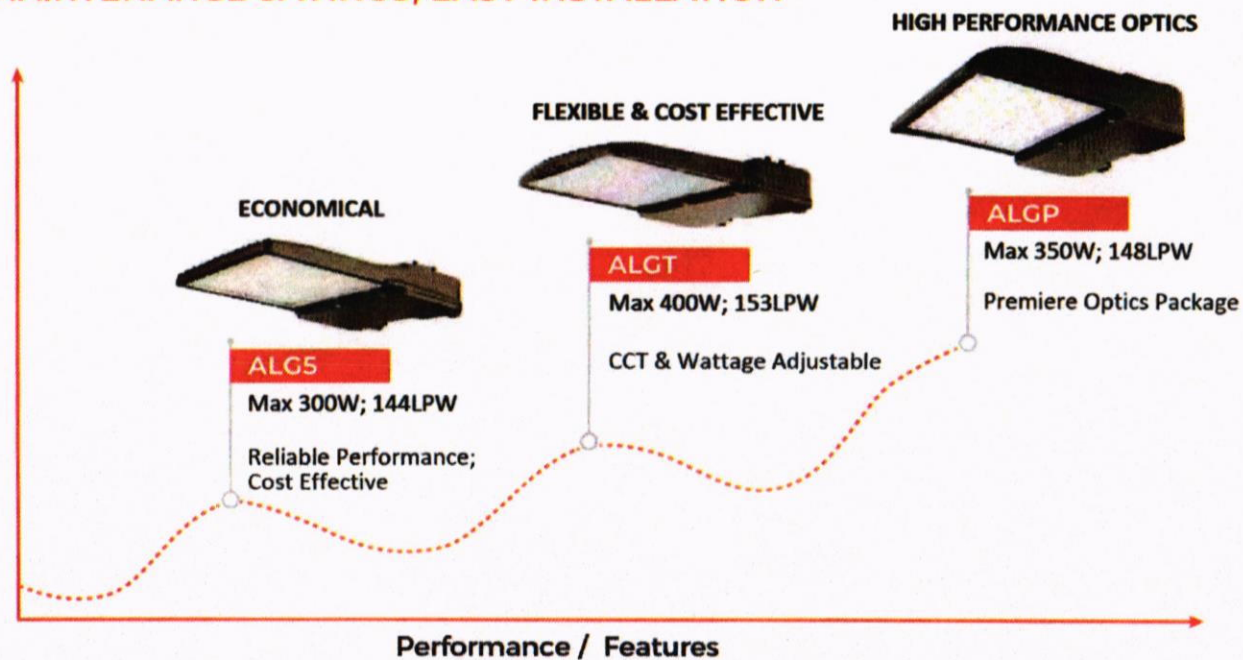

	ALG5	ALGT	ALGP
Input Voltage	120-277VAC or 347-480VAC	120-277VAC or 347-480VAC	120-277VAC or 347-480VAC
Wattage	100W 150W 180W 250W 300W	100W 140W 180W 250W 300W 400W	100W 150W 200W 240W 300W 350W
Output Lumens	14,200lm 21,000lm 26,000lm 36,000lm 42,000 lm	16,200lm 23,500lm 28,000lm 38,000lm 46,000 lm 61,000 lm	14,800lm 22,200lm 28,800lm 35,500lm 43,700lm 51,000 lm
Photometrics	Type III, IV, V	Type II, III, IV, V	Type III, IV, V 6H x 7V
Temperature Rating	Up to 40°C	Up to 45°C	Up to 45°C
Warranty	5 Years	5 Years	10 Years

AREA LIGHT SERIES
OUTDOOR

ALG5

Contractor Series

- Durable one-piece die-cast aluminum housing and polycarbonate lens
- Available in IES Type III, IV, V distributions
- 10KA(@120-277V) or 20KA(@347-480V) surge protection
- 0-10V dimming driver standard for 10% to 100% dimming
- Operating temperature is -40C to 40C
- Five easy mounting options



Small Size 100W



Medium Size 150W&180W



Large Size 250W&300W

Optional PIR sensor and twist-lock photocell allows for security and energy saving

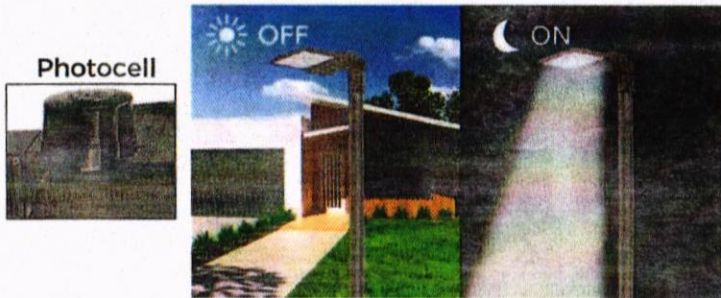

THE IDEAL BALANCE OF
PERFORMANCE AND CONTROL
OPTIONS AT COMPETITIVE PRICING

WATTAGE SWITCH

The built-in Wattage switch can be used in different applications with much flexibility to adjust On-field and meanwhile reduce SKUs



Save Time



Save Money



Dimmable



Harsh Weather



High Bright



IP65

ALGP High Performance Series



- Durable one-piece die-cast aluminum housing and polycarbonate lens.
- Available in IES Type III, IV, V distributions
- 10KA(@120-277V) or 20KA(@347-480V) surge protection
- 0-10V dimming driver standard for 10% to 100% dimming
- Operating temperature is -40C to 45C.
- Five easy to install installation options available



Backlight Control Systems

- Provide excellent back light control lighting effect
- Neighbor-friendly and reduces the chance of unhappiness between each other

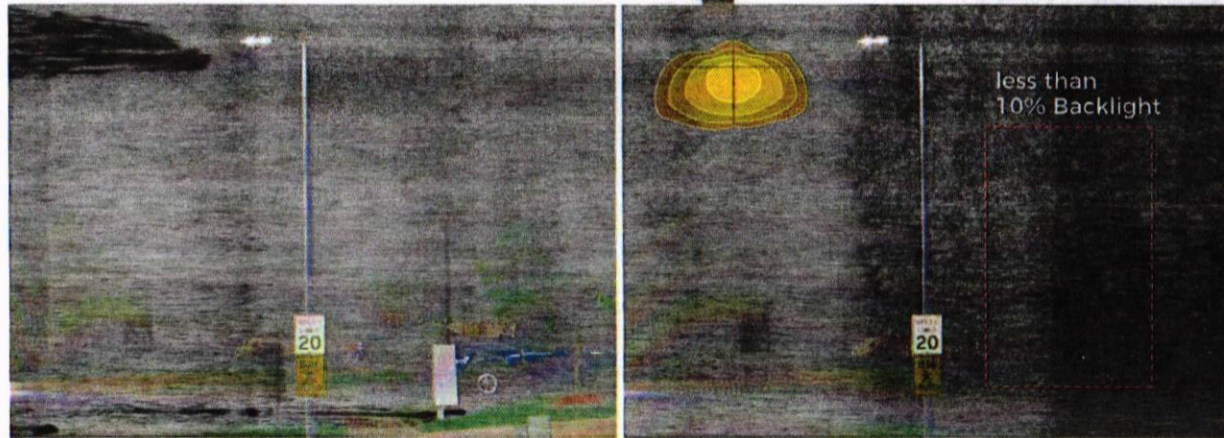

Optical Distributions

- Wider illumination across the curb line results in increased poles spacing, and hence, reduces material, operational and installation cost
- Even distribution of light enhances visual acuity
- Wide and squared off corners allow simplification of layout design that improves uniformity by decreasing contrast in the transition zones between the two poles

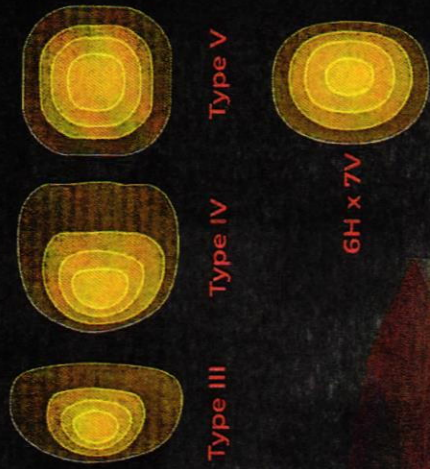

6H x 7V



ALGT Tunable Series

- Durable one-piece die-cast aluminum housing and polycarbonate lens
- Color Temperature adjustable: 3000K, 4000K, 5000K
- Available in IES Type II, III, IV, V distributions
- Four adjustable Wattage levels available for each model
- 0-10V dimming driver standard for 10% to 100% dimming
- 10KA(@120-277V) or 20KA(@347-480V) surge protection
- Operating temperature is -40C to 45C



Medium Size 100W&140W&180W



Large Size 250W&300W&400W

WATTAGE & CCT SELECTABLE OPTIONS

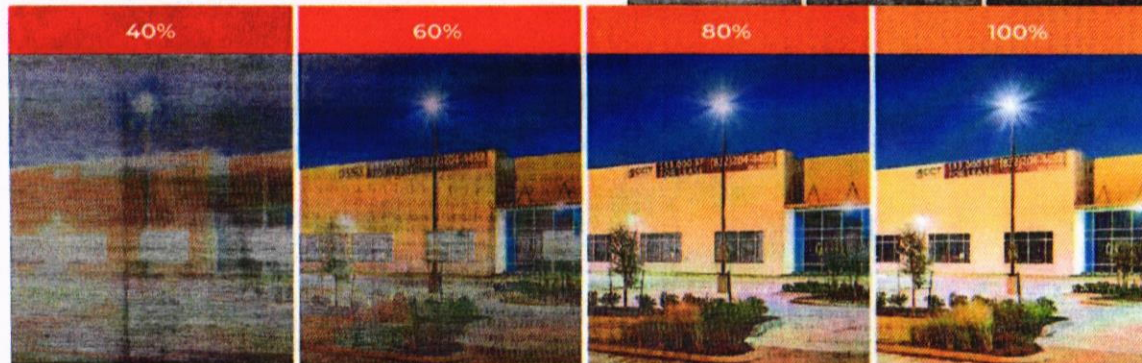

SUPERIOR CONSTRUCTION & HOUSING

Adjustable Mounting Accessories

45°
15°
0°

CCT & POWER FIELD-ADJUSTABLE

POWER CCT
LV1 5KK
LV2 4KK
LV3 5KK
LV4

PIR Motion Sensor (Optional)

Photometry

Four distribution options with best-in-class performance, delivering the highest in light utilization with the lowest BUG ratings and no glare

Type II Type II Type IV Type V

Plug-and-Play PIR Sensor

Backlight Control

For stringent light trespass requirements and the ultimate level of backlight control, a house side shield accessory is available for factory or field installation to greatly reduce and also enhances visual comfort

AREA LIGHT SERIES
OUTDOOR

MOUNTING OPTIONS

A wide variety of mounting options are offered to meet your outdoor lighting needs and challenges.



Easy Installation

All mounting options are field interchangeable & can be installed quickly and easily to minimize labor costs

Standard versatile mounting arm accommodates multiple drilling patterns as well as square and round poles

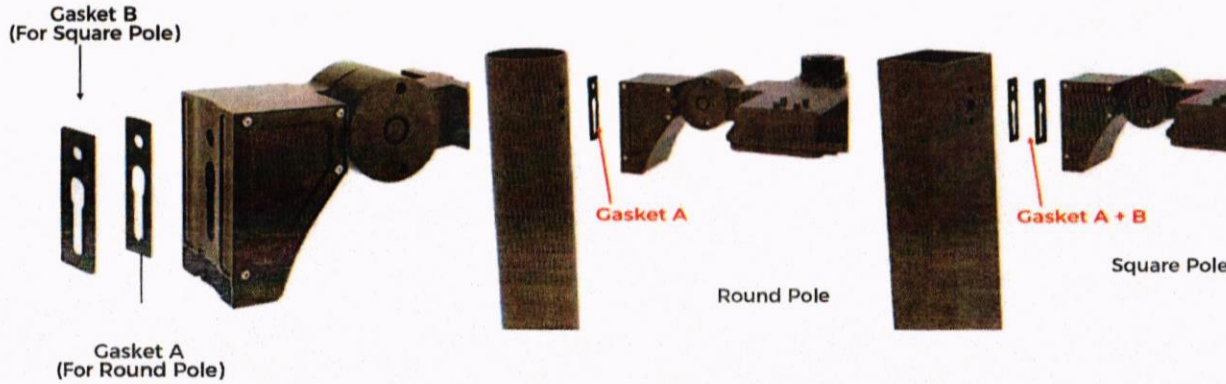

EPA OF AREA LIGHT

The efficient wave design is sturdy and made with safety in mind. We know that EPA matters for your outdoor lighting solutions and our ALG Series delivers a safely designed area light that will stand the test of time

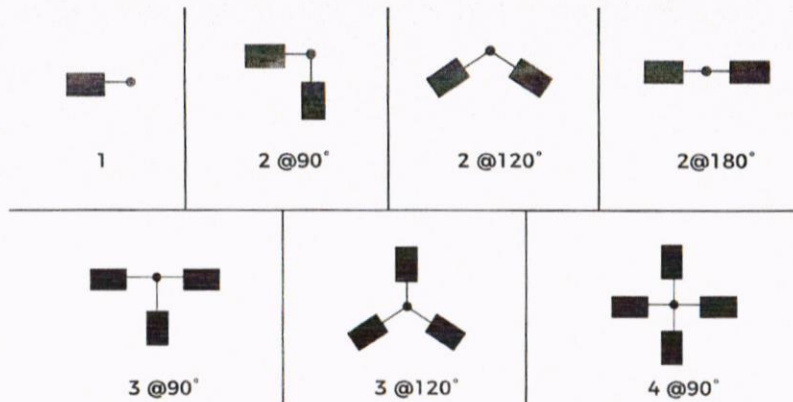

50' Maximum Mounting Height

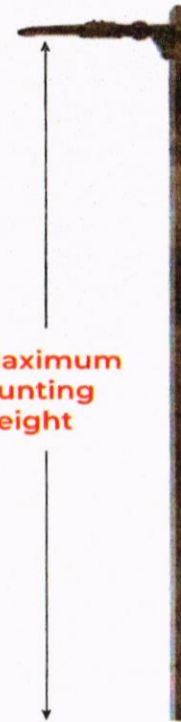

AREA LIGHT SERIES
OUTDOOR

Mounting Kits



SQDAL08-A
Adjustable pole mount kit, suitable for round or square poles



SQDAL08-A
Fixed pole mount kit, suitable for round or square poles



SPAL04DB
Slipfitter mount kit, fits 2 3/8" tenon



YKFD07DC
Yoke mount kit



WMDAL08-A
Wall mount kit



SQA-ALDA
Pole Bracket Accessories- Horizontal and Vertical Adjustment Adapter

External Tenon Bracket For Slipfitter Mount



SP-TR-D
Pole top bracket accessories-Tenon & Yoke Adapter, dark bronze



SQ/R-SP-D
Horizontal Wall or Square or Round pole mount with 2-3/8" Tenon Bracket, dark bronze

Internal Tenon Adapter For Square & Round Poles For Slipfitter Mount



4SQR-SP-D
Pole mount single 2 3/8" tenon, top mount vertical for 4" round pole, dark bronze



4SQ-SP-D
Pole mount single 2 3/8" tenon, top mount vertical for 4" square pole, dark bronze



5SQR-SP-D
Pole mount single 2 3/8" tenon, top mount vertical for 5" round pole, dark bronze



5SQ-SP-D
Pole mount single 2 3/8" tenon, top mount vertical for 5" square pole, dark bronze

Round External Mount Horizontal Tenon For Slipfitter Mount



R60-SP2-90-D
Twin Spoke 90° Horizontal Tenon Adapter, dark bronze



R60-SP3-120-D
Triple Spoke 120° Horizontal Tenon Adapter, dark bronze



R60-SP2-180-D
Twin Spoke 180° Horizontal Tenon Adapter, dark bronze



R60-SP4-90-D
Quad spoke 90° Horizontal Tenon Adapter, dark bronze



R60-SP3-90-D
Triple Spoke 90° Horizontal Tenon Adapter, dark bronze

Glare Shield Accessories



SC-AL04-SL-DA
Backlight control, Dark bronze, suit for ALG5-small size, dark bronze



SC-AL04-ML-DA
Backlight control, Dark bronze, suit for ALG5-medium size, dark bronze



SC-AL04-LL-DA
Backlight control, Dark bronze, suit for ALGP, ALGT-small size, dark bronze



SC-AL06-SL-DA-S
Backlight control, Dark bronze, suit for ALGP, ALGT-small size, dark bronze



SC-AL06-LL-DA-S
Backlight control, Dark bronze, suit for ALGP, ALGT-large size, dark bronze



SC-AL06-SL-DA-F
Glare Shield control, Dark bronze, suit for ALGP, ALGT-small size, dark bronze



SC-AL06-LL-DA-F
Glare Shield control, Dark bronze, suit for ALGP, ALGT-large size, dark bronze

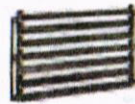

SC-AL08-150W-BA
Backlight control, Black, suit for ALGT, dark bronze

Control Accessories



BR1823-B-D
PIR Sensor, 120-277V, Optional for bluetooth



MSANT12VPH01
Plug-and-Play PIR Sensor, 12-24V, Optional for bluetooth, suit for ALGT



MSANT12VMH01
Plug-and-Play Microwave Sensor, 12-24V, Optional for bluetooth, suit for ALGT



MSPI-PSUNVBT
NEMA 3-pin photocell 120-277V or 480VAC



JL-241C
NEMA 7-pin photocell 120-277V

Pole Accessories

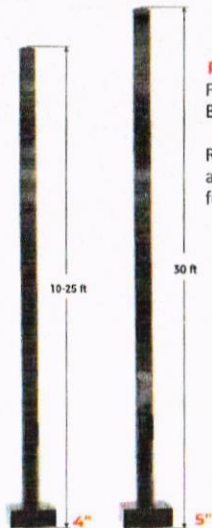

Round Pole
Finish: Dark Bronze, Black, White; 4", 5"

Round straight steel pole is a general purpose light pole for up to 30' mount heights

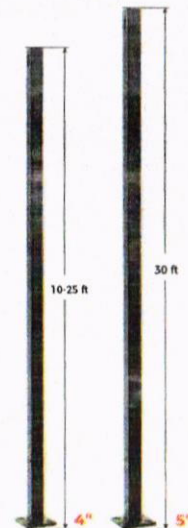

Square Pole
Finish: Dark Bronze, Black, White; 4", 5"

Square straight steel pole is a general purpose light pole for up to 30' mount heights



WIRELESS CONTROLS

Arcadia Lighting is dedicated towards offering the best control solutions for ease of compatibility, ease of use, ease of installation, and quality for the best safety and money saving options for your lighting needs.

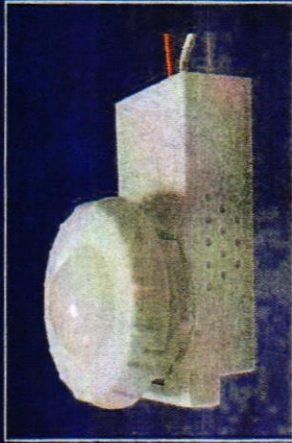

Integrated & Remote Motion Sensors
Wireless Commissioning Tool Twist-lock
photocell and more.



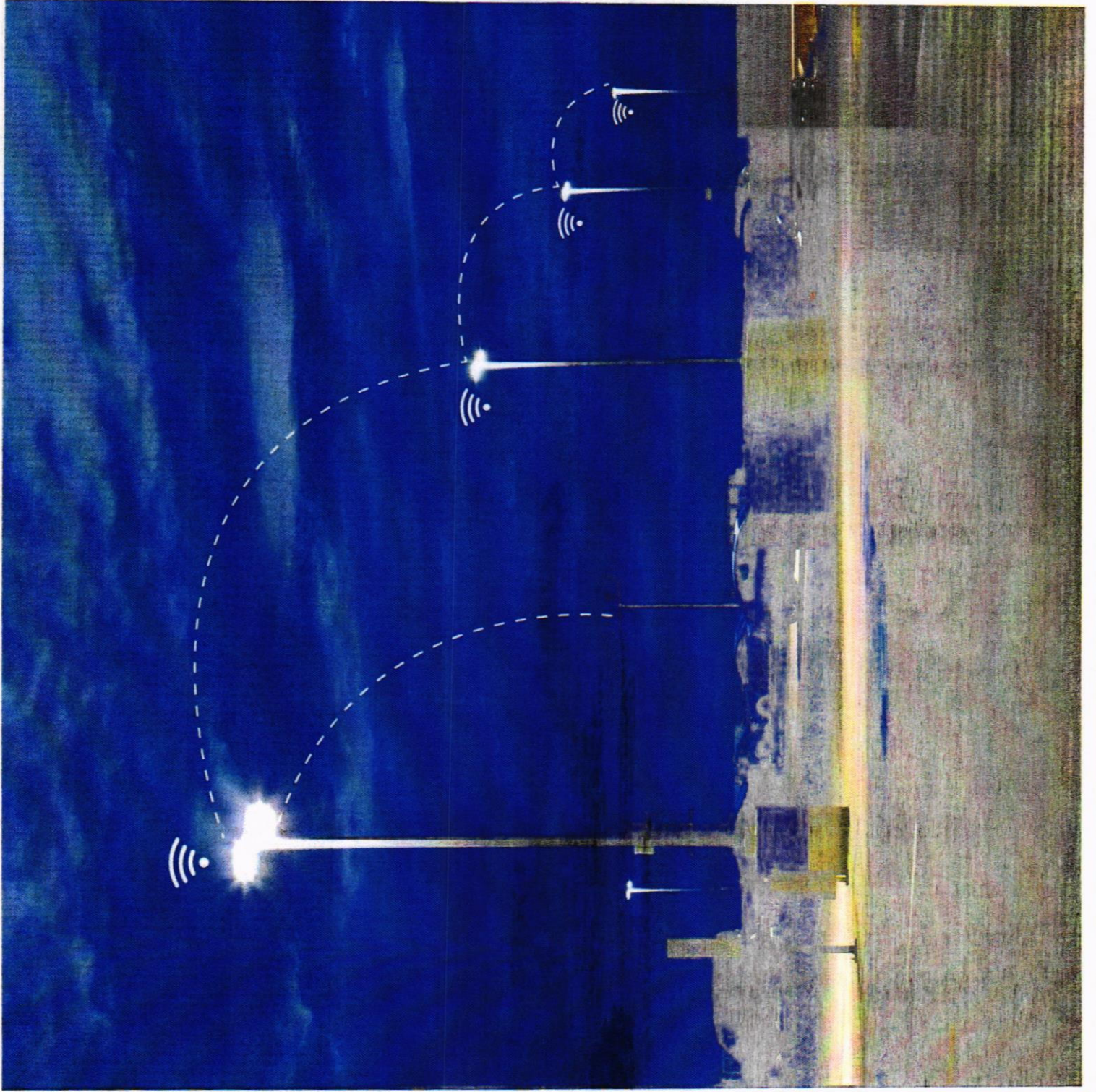

KL00
SOLUTIONS

INFO@KL00.SOLUTIONS

(822)384-5500

WWW.KL00.SOLUTIONS



AREA LIGHT ALGT SERIES

Features & Benefits

Rugged One-Piece Die-Cast Aluminum Housing with Complete Heat Sink

Suitable for Mounting Heights Ranging from 26-50'; Ambient from -40° F to 113° F

Adjustable Power and CCT

Round Pole, Square Pole, Slipfitter or Wall Mount Included

Available in Type 2, Type 3, Type 4, and Type 5 Light Distributions

Remote PIR Sensor, Photocell

Mounting Adapters for all Applications

UL for Wet Location, IP66 Rated

The Optics can Conform to Dark Sky Requirement

Estimated 100,000-hour LED lifespan based on IES LM-80 and TM-21 Calculations

5-Year Limited Warranty; Extended Labor Warranty Available Upon Request

Medium Size: 100W/140W/180W



Large Size: 250W/300W/400W

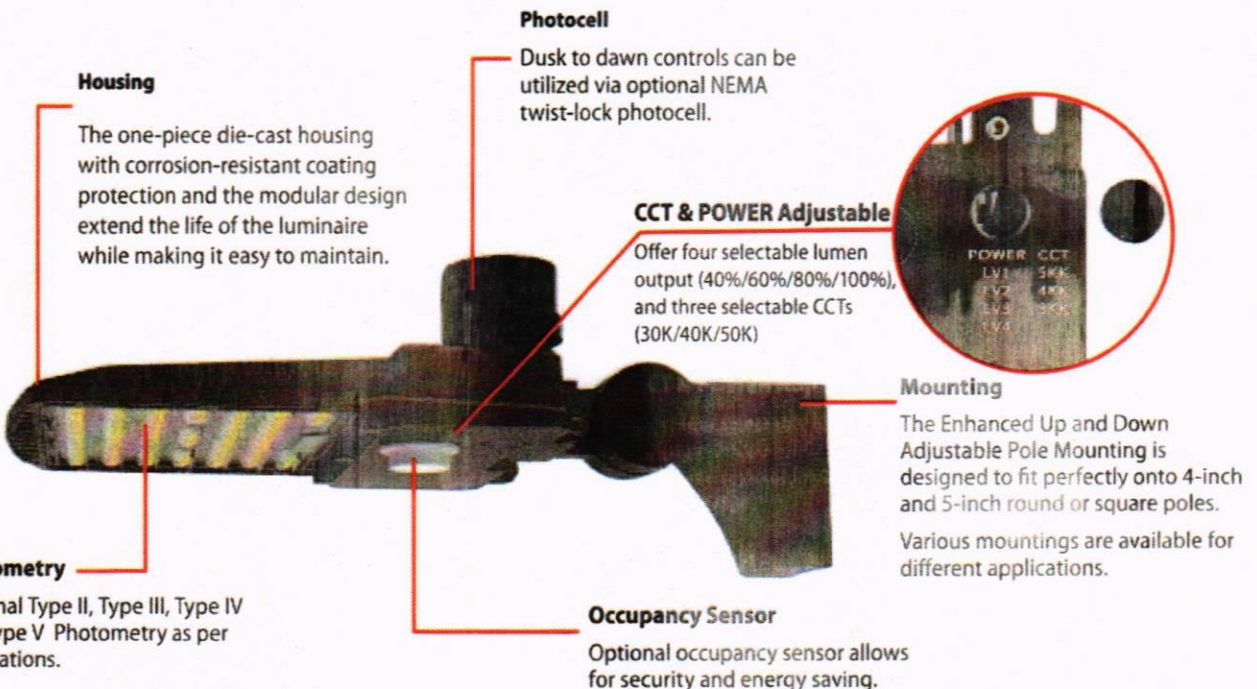

Technical Parameters

Power	Light Output	Input	Operating Temperature	Efficacy
100W - 400W	6,560 lm - 260,000 lm	120-277V / 347/480V	-40° F to 113° F	Up to 175 lm/W

Color Temperature	CRI	Certifications	Photocell	Motion Sensor
3000K, 4000K, 5000K	70 CRI	UL Wet Location Listed	Twist Lock	Bi-Level PIR Sensor

Driver	Surge Protection	Light Distribution	Finish
1-10V Dimming	10K	Types 2, 3, 4, 5	DB, W, B, SG

Note: 0-10V Dimming Driver Available Upon Request

Performance Data

		ALGT-100W							
Setting	System Watts	Dist. Type	CRI	3000K		4000K		5000K	
				Lumens	LPW	Lumens	LPW	Lumens	LPW
100%	100W	2	70	14500 lm	145 lm/W	15800 lm	158 lm/W	15000 lm	150 lm/W
		3	70	14500 lm	145 lm/W	15800 lm	158 lm/W	15000 lm	150 lm/W
		4	70	14500 lm	145 lm/W	15800 lm	158 lm/W	15000 lm	150 lm/W
		5	70	15100 lm	151 lm/W	16000 lm	160 lm/W	15600 lm	156 lm/W
80%	80W	2	70	12000 lm	150 lm/W	13000 lm	163 lm/W	12500 lm	156 lm/W
		3	70	12000 lm	150 lm/W	13000 lm	163 lm/W	12500 lm	156 lm/W
		4	70	12000 lm	150 lm/W	13000 lm	163 lm/W	12500 lm	156 lm/W
		5	70	12500 lm	156 lm/W	13300 lm	166 lm/W	12800 lm	160 lm/W
60%	60W	2	70	9300 lm	155 lm/W	10000 lm	167 lm/W	9600lm	160 lm/W
		3	70	9300 lm	155 lm/W	10000 lm	167 lm/W	9600lm	160 lm/W
		4	70	9300 lm	155 lm/W	10000 lm	167 lm/W	9600lm	160 lm/W
		5	70	9600 lm	160 lm/W	10200 lm	170 lm/W	9850lm	164 lm/W
40%	40W	2	70	6400 lm	160 lm/W	6800 lm	170 lm/W	6560lm	164 lm/W
		3	70	6400 lm	160 lm/W	6800 lm	170 lm/W	6560lm	164 lm/W
		4	70	6400 lm	160 lm/W	6800 lm	170 lm/W	6560lm	164 lm/W
		5	70	6560 lm	164 lm/W	7000 lm	175 lm/W	6700lm	168 lm/W

ALGT-140W									
Setting	System Watts	Dist. Type	CRI	3000K		4000K		5000K	
				Lumens	LPW	Lumens	LPW	Lumens	LPW
100%	140W	2	70	20000lm	147 lm/W	23000lm	164 lm/W	21000lm	150 lm/W
		3	70	20000lm	147 lm/W	23000lm	164 lm/W	21000lm	150 lm/W
		4	70	20000lm	147 lm/W	23000lm	164 lm/W	21000lm	150 lm/W
		5	70	21000lm	150 lm/W	23500lm	168 lm/W	21500lm	154 lm/W
80%	120W	2	70	18000lm	150 lm/W	20000lm	167 lm/W	18500lm	154 lm/W
		3	70	18000lm	150 lm/W	20000lm	167 lm/W	18500lm	154 lm/W
		4	70	18000lm	150 lm/W	20000lm	167 lm/W	18500lm	154 lm/W
		5	70	18500lm	154 lm/W	20500lm	171 lm/W	19000lm	158 lm/W
60%	90W	2	70	13800lm	153 lm/W	15200lm	169 lm/W	14200lm	158 lm/W
		3	70	13800lm	153 lm/W	15200lm	169 lm/W	14200lm	158 lm/W
		4	70	13800lm	153 lm/W	15200lm	169 lm/W	14200lm	158 lm/W
		5	70	14000lm	156 lm/W	15600lm	172 lm/W	14500lm	161 lm/W
40%	60W	2	70	9400lm	157 lm/W	10300lm	172 lm/W	9700lm	162 lm/W
		3	70	9400lm	157 lm/W	10300lm	172 lm/W	9700lm	162 lm/W
		4	70	9400lm	157 lm/W	10300lm	172 lm/W	9700lm	162 lm/W
		5	70	9600lm	160 lm/W	10500lm	175 lm/W	10000lm	167 lm/W

ALGT-180W									
Setting	System Watts	Dist. Type	CRI	3000K		4000K		5000K	
				Lumens	LPW	Lumens	LPW	Lumens	LPW
100%	180W	2	70	24800lm	138 lm/W	27000lm	150 lm/W	25200lm	140 lm/W
		3	70	24800lm	138 lm/W	27000lm	150 lm/W	25200lm	140 lm/W
		4	70	24800lm	138 lm/W	27000lm	150 lm/W	25200lm	140 lm/W
		5	70	25500lm	142 lm/W	28000lm	156 lm/W	26000lm	144 lm/W
80%	144W	2	70	20200lm	140 lm/W	22000lm	153 lm/W	20600lm	143 lm/W
		3	70	20200lm	140 lm/W	22000lm	153 lm/W	20600lm	143 lm/W
		4	70	20200lm	140 lm/W	22000lm	153 lm/W	20600lm	143 lm/W
		5	70	20800lm	144 lm/W	22800lm	158 lm/W	21000lm	146 lm/W
60%	108W	2	70	15300lm	142 lm/W	16800lm	156 lm/W	15700lm	145 lm/W
		3	70	15300lm	142 lm/W	16800lm	156 lm/W	15700lm	145 lm/W
		4	70	15300lm	142 lm/W	16800lm	156 lm/W	15700lm	145 lm/W
		5	70	15800lm	146 lm/W	17300lm	160 lm/W	16200lm	150 lm/W
40%	72W	2	70	10500lm	146 lm/W	11500lm	160 lm/W	10800lm	150 lm/W
		3	70	10500lm	146 lm/W	11500lm	160 lm/W	10800lm	150 lm/W
		4	70	10500lm	146 lm/W	11500lm	160 lm/W	10800lm	150 lm/W
		5	70	10800lm	150 lm/W	11800lm	164 lm/W	11000lm	153 lm/W

ALGT-250W									
Setting	System Watts	Dist. Type	CRI	3000K		4000K		5000K	
				Lumens	LPW	Lumens	LPW	Lumens	LPW
100%	250W	2	70	33500lm	134 lm/W	37000lm	148 lm/W	34500lm	138 lm/W
		3	70	33500lm	134 lm/W	37000lm	148 lm/W	34500lm	138 lm/W
		4	70	33500lm	134 lm/W	37000lm	148 lm/W	34500lm	138 lm/W
		5	70	34500lm	138 lm/W	38000lm	152 lm/W	35500lm	142 lm/W
80%	200W	2	70	27500lm	138 lm/W	30400lm	152 lm/W	28400lm	142 lm/W
		3	70	27500lm	138 lm/W	30400lm	152 lm/W	28400lm	142 lm/W
		4	70	27500lm	138 lm/W	30400lm	152 lm/W	28400lm	142 lm/W
		5	70	28000lm	140 lm/W	31000lm	155 lm/W	28800lm	144 lm/W
60%	150W	2	70	21300lm	142 lm/W	23200lm	155 lm/W	21800lm	145 lm/W
		3	70	21300lm	142 lm/W	23200lm	155 lm/W	21800lm	145 lm/W
		4	70	21300lm	142 lm/W	23200lm	155 lm/W	21800lm	145 lm/W
		5	70	21800lm	145 lm/W	23800lm	159 lm/W	22500lm	150 lm/W
40%	100W	2	70	14500lm	145 lm/W	16000lm	160 lm/W	14800lm	148 lm/W
		3	70	14500lm	145 lm/W	16000lm	160 lm/W	14800lm	148 lm/W
		4	70	14500lm	145 lm/W	16000lm	160 lm/W	14800lm	148 lm/W
		5	70	15000lm	150 lm/W	16500lm	165 lm/W	15500lm	155 lm/W

ALGT-300W									
Setting	System Watts	Dist. Type	CRI	3000K		4000K		5000K	
				Lumens	LPW	Lumens	LPW	Lumens	LPW
100%	300W	2	70	41000lm	137 lm/W	45000lm	150 lm/W	42000lm	140 lm/W
		3	70	41000lm	137 lm/W	45000lm	150 lm/W	42000lm	140 lm/W
		4	70	41000lm	137 lm/W	45000lm	150 lm/W	42000lm	140 lm/W
		5	70	42500lm	142 lm/W	46000lm	153 lm/W	43500lm	145 lm/W
80%	240W	2	70	33600lm	140 lm/W	37000lm	154 lm/W	34500lm	144 lm/W
		3	70	33600lm	140 lm/W	37000lm	154 lm/W	34500lm	144 lm/W
		4	70	33600lm	140 lm/W	37000lm	154 lm/W	34500lm	144 lm/W
		5	70	34500lm	144 lm/W	38000lm	158 lm/W	35500lm	148 lm/W
60%	180W	2	70	26000lm	144 lm/W	28600lm	159 lm/W	26600lm	148 lm/W
		3	70	26000lm	144 lm/W	28600lm	159 lm/W	26600lm	148 lm/W
		4	70	26000lm	144 lm/W	28600lm	159 lm/W	26600lm	148 lm/W
		5	70	26600lm	148 lm/W	29700lm	165 lm/W	27500lm	153 lm/W
40%	120W	2	70	18000lm	150 lm/W	20000lm	167 lm/W	18500lm	154 lm/W
		3	70	18000lm	150 lm/W	20000lm	167 lm/W	18500lm	154 lm/W
		4	70	18000lm	150 lm/W	20000lm	167 lm/W	18500lm	154 lm/W
		5	70	18500lm	154 lm/W	20800lm	173 lm/W	19000lm	158 lm/W

ALGT-400W									
Setting	System Watts	Dist. Type	CRI	3000K		4000K		5000K	
				Lumens	LPW	Lumens	LPW	Lumens	LPW
100%	400W	2	70	60500lm	151 lm/W	60000lm	150 lm/W	34500lm	138 lm/W
		3	70	60500lm	151 lm/W	60000lm	150 lm/W	34500lm	138 lm/W
		4	70	60500lm	151 lm/W	60000lm	150 lm/W	34500lm	138 lm/W
		5	70	61000lm	153 lm/W	60800lm	152 lm/W	35500lm	142 lm/W
80%	320W	2	70	49000lm	153 lm/W	48600lm	152 lm/W	28400lm	142 lm/W
		3	70	49000lm	153 lm/W	48600lm	152 lm/W	28400lm	142 lm/W
		4	70	49000lm	153 lm/W	48600lm	152 lm/W	28400lm	142 lm/W
		5	70	50000lm	156 lm/W	49500lm	155 lm/W	28800lm	144 lm/W
60%	240W	2	70	37600lm	157 lm/W	37200lm	155 lm/W	21800lm	145 lm/W
		3	70	37600lm	157 lm/W	37200lm	155 lm/W	21800lm	145 lm/W
		4	70	37600lm	157 lm/W	37200lm	155 lm/W	21800lm	145 lm/W
		5	70	38500lm	160 lm/W	37600lm	157 lm/W	22500lm	150 lm/W
40%	160W	2	70	26000lm	163 lm/W	25600lm	160 lm/W	14800lm	148 lm/W
		3	70	26000lm	163 lm/W	25600lm	160 lm/W	14800lm	148 lm/W
		4	70	26000lm	163 lm/W	25600lm	160 lm/W	14800lm	148 lm/W
		5	70	26500lm	166 lm/W	26000lm	163 lm/W	15500lm	155 lm/W

Ordering Information *Example: ALGT-140W-XXK-PM-T3*

(Optional)

Model	Wattage	Voltage	CCT	Finish	Mounting	Distribution	Controls
ALGT Area Light ALGT Series	100W 140W 180W 250W 300W 400W	Blank 120-277V HV 347/480V	XXK 3000k/ 4000K/ 5000k 40K 4000K 50K 5000K	Blank Dark Bronze W White B Black SG Silver Gray	PM Pole Mount SP Slipfitter WM Wall Mount PMA Adjustable Pole Mount	T2 Type 2 T3 Type 3 T4 Type 4 T5 Type 5	P Photocell M Motion Sensor

Note:

1. Pole Mount Includes Square & Round Pole Adapter
2. 100W is limited to 120-277V Input Only
3. 40W when voltage is 120-277V; 45W when voltage is 347/480V
4. 70W when voltage is 120-277V; 75W when voltage is 347/480V



T: (832) 384-5566

M: info@kloo.solutions

www.kloo.solutions

Product Dimensions

**100W/140W/180W
(Adjustable Square Mount)**

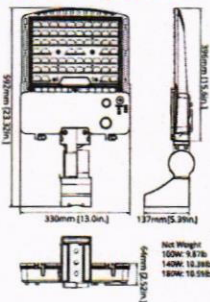

**100W/140W/180W
(Slipfitter Mount)**

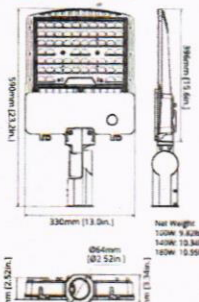

**100W/140W/180W
(Wall Mount)**

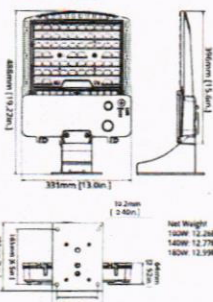

**100W/140W/180W
(Pole Mount)**

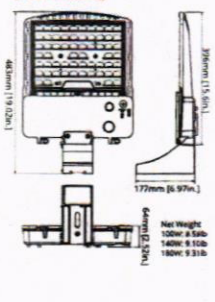

**100W/140W/180W
(Yoke Mount)**

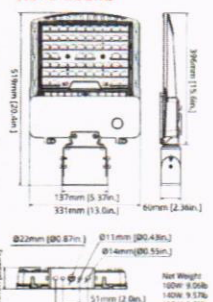

**250W/300W/400W
(Adjustable Square Mount)**

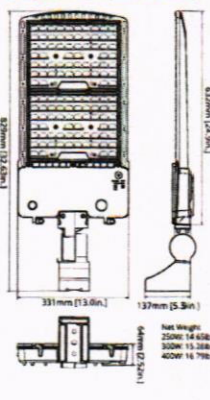

**250W/300W/400W
(Slipfitter Mount)**

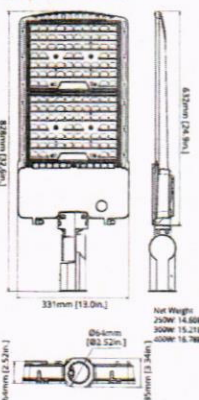

**250W/300W/400W
(Wall Mount)**

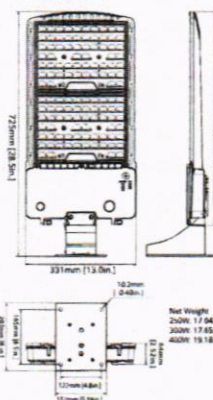

**250W/300W/400W
(Pole Mount)**

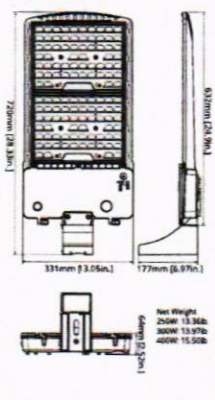

**250W/300W/400W
(Yoke Mount)**

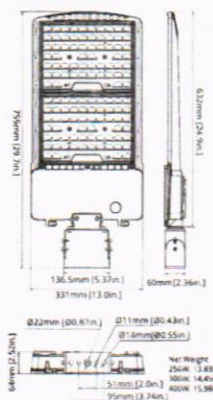

Mounting



Arm Mount
(4" and 5" Square and Round poles)
Standard versatile mounting arm is simple to install and can be used with existing poles for retrofit installations.



Slipfitter Mount
An optional cast aluminum mast arm adapter secures fixture head to nominal 2-3/8" O.D. horizontal steel tenon arm.

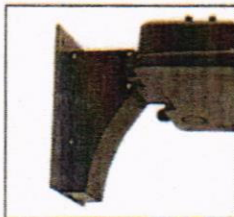

Wall Mount
Wall Mount is easy to install for direct wall mounting with 1/2" conduit wiring or standard J-box mounting.



Yoke Mount
Die-cast aluminum trunnion is easily adapted to many surfaces and allows easy fixture aiming angles.



Adjustable Arm Mount
Standard versatile mounting arm is simple to install and can be used with existing poles for retrofit installations.

Mounting Dimensions

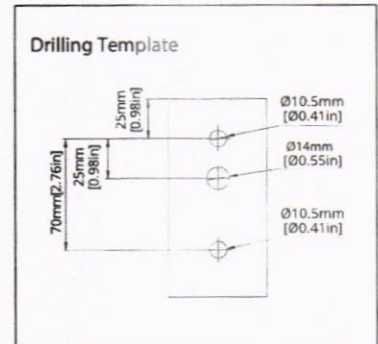
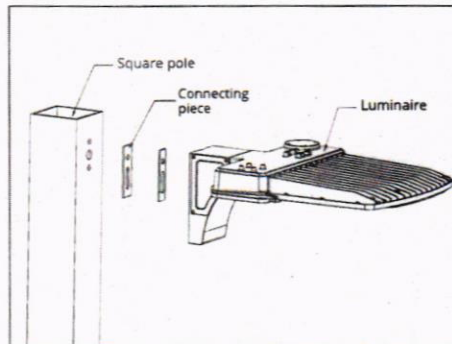
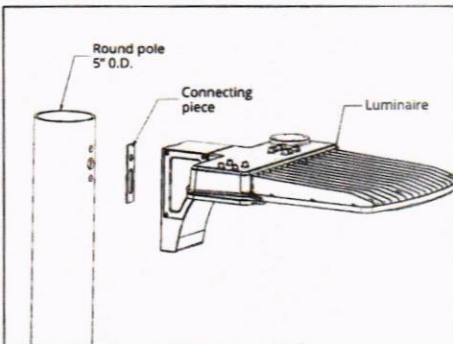

Photometrics

Kloo Solutions offers a complete set of optical systems to meet every site lighting requirement. These systems provide remarkable flexibility in precisely matching light distribution patterns to specific site requirements.

Type 2 optics are ideal for applications where there is a need to space the luminaires further apart along a road or pathway. The light distribution pattern is optimized for elongated areas, allowing for greater pole spacing without sacrificing lighting quality.

Type 3 optics produce an asymmetrical pattern that directs the majority of the light forward and equally on both sides of the luminaire. In a back-to-back configuration, it creates a rectangular pattern which can extend pole spacings.

Type 4 is suitable for applications where light is primarily required forward with minimal backlight. Typical installations include perimeter poles.

Type 5 optics produce a symmetrical square distribution pattern that distributes light equally on all sides of the luminaire. Type 5 luminaires is universal for most area lighting applications

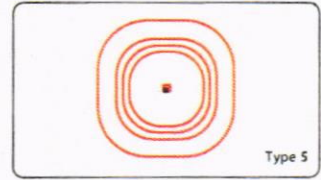
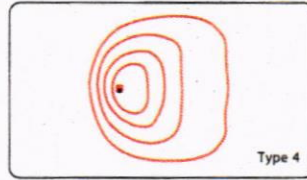
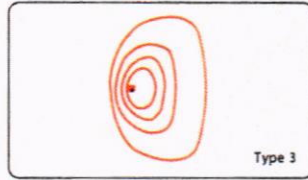
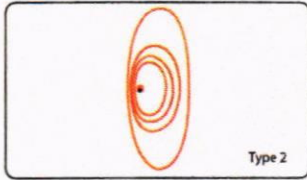

Additional Mounting Accessories

POLE BRACKET - For mounting luminaire on an existing pole			
	<p>4' Square Pole Mount with 2-3/8" O.D. Tenon NO. 45Q-SP-D Finish: Dark Bronze USE: For use with square, non-tapered steel and aluminum poles. Furnished with four 5/16" hex head stainless-steel bolts. Vertical tenon measures 2-3/8" O.D. and is made of steel tubing. Fixtures mounted to this bracket can be adjusted both vertically and horizontally.</p>		<p>4' Round Pole Mount with 2-3/8" O.D. Tenon NO. 45QR-SP-D Finish: Dark Bronze USE: For use with round, non-tapered steel and aluminum poles. Furnished with three 3/8" hex head stainless-steel bolts. Vertical tenon measures 2-3/8" O.D. and is made of steel tubing. Fixtures mounted to this bracket can be adjusted both vertically and horizontally.</p>
	<p>5' Square Pole Mount with 2-3/8" O.D. Tenon NO. 55Q-SP-D Finish: Dark Bronze USE: For use with square, non-tapered steel and aluminum poles. Furnished with four 5/16" hex head stainless-steel bolts. Vertical tenon measures 2-3/8" O.D. and is made of steel tubing. Fixtures mounted to this bracket can be adjusted both vertically and horizontally.</p>		<p>5' Round Pole Mount with 2-3/8" O.D. Tenon NO. 55QR-SP-D Finish: Dark Bronze USE: For use with round, non-tapered steel and aluminum poles. Furnished with three 3/8" hex head stainless-steel bolts. Vertical tenon measures 2-3/8" O.D. and is made of steel tubing. Fixtures mounted to this bracket can be adjusted both vertically and horizontally.</p>
	<p>Pole Bracket Accessories - Angle-Adjustment Adapter NO. 50A-ADA Finish: Dark Bronze USE: Durable brackets are engineered to provide versatile mounting options. These arms are made from rugged die-cast aluminum. They allow optimal positioning of the light fixture to maximize the lighting effectiveness vertically and horizontally.</p>		<p>Pole Bracket accessories - Tenon & Yoke Adaptor NO. 5P-76-D Finish: Dark Bronze USE: The 2-3/8" OD Tenon Mount Adaptor for Yoke Fixtures is designed to mount MESTER light fixtures that are equipped with a yoke mount onto a 2-3/8" OD tenon. It may be utilized with the Master Fixed Light Series of light fixtures.</p>
	<p>Horizontal Wall or Square or Round pole mount with 2-3/8" Tenon Bracket NO. 50R6-SP-D Finish: Dark Bronze USE: This tenon bracket can be installed onto a wall, square pole, round pole. Provides wiring access and allows 2-3/8" O.D. tenon to mount a fixture with our adjustable y-clip. Suggested 3/8" diameter bolts for mounting.</p>		
WALL BRACKET - Attaches to any flat surface. Provides wiring access.		Mid-Pole Tenon Bracket	
	<p>90° Wall Mount Bracket with 2-3/8" O.D. Tenon NO. 90W-SP-D Finish: Dark Bronze USE: The 90° wall mount bracket with 2-3/8" tenon attaches an MESTER headlight to almost any surface: wall, roof, or wood pole. Provides wiring access and allows 2-3/8" O.D. tenon to mount a fixture with our adjustable y-clip. Suggested 3/8" diameter bolts for mounting. Mounting holes are spaced 3-1/4" apart.</p>		<p>2-3/8" OD Horizontal Tenon Mid-Pole Bracket NO. 5Q-SP-D Finish: Dark Bronze USE: 2-3/8" OD Horizontal Tenon Mid-Pole Bracket is designed to mount light fixtures that are equipped with an adjustable y-clip onto a 2-3/8" OD horizontal tenon.</p>
Round External Mount Horizontal Tenon - To mount 2-3/8" fixtures on a existing pole			
	<p>Double 90° Horizontal Tenon Adaptor NO. 90A-SP2-90-D Finish: Dark Bronze USE: This Bracket is designed to mount over 2-3/8" (60mm) O.D. vertical tenon. Two fixtures can be mounted to the Round External Mount Horizontal Tenon and adjusted horizontally.</p>		<p>Triple 120° Horizontal Tenon Adaptor NO. 90A-SP3-150-D Finish: Dark Bronze USE: This Bracket is designed to mount over 2-3/8" (60mm) O.D. vertical tenon. Three fixtures can be mounted to the Round External Mount Horizontal Tenon and adjusted horizontally.</p>
	<p>Double 180° Horizontal Tenon Adaptor NO. 90A-SP2-180-D Finish: Dark Bronze USE: This Bracket is designed to mount over 2-3/8" (60mm) O.D. vertical tenon. Two fixtures can be mounted to the Round External Mount Horizontal Tenon and adjusted horizontally.</p>		<p>Quad 90° Horizontal Tenon Adaptor NO. 90A-SP4-90-D Finish: Dark Bronze USE: This Bracket is designed to mount over 2-3/8" (60mm) O.D. vertical tenon. Four fixtures can be mounted to the Round External Mount Horizontal Tenon and adjusted horizontally.</p>
	<p>Triple 90° Horizontal Tenon Adaptor NO. 90A-SP3-90-D Finish: Dark Bronze USE: This Bracket is designed to mount over 2-3/8" (60mm) O.D. vertical tenon. Three fixtures can be mounted to the Round External Mount Horizontal Tenon and adjusted horizontally.</p>		



Understanding 1–5 Foot-Candles

What is a Foot-Candle?

A foot-candle (fc) measures how much light reaches a surface. 1 foot-candle equals the light from one candle at one foot away. It describes how bright a floor, table, or workspace appears.

1 Foot-Candle

Similar to bright moonlight. You can see where you are walking and recognize large objects, but reading small print is difficult.

- Emergency lighting
- Outdoor safety lighting
- After-hours warehouse

2 Foot-Candles

Slightly brighter than moonlight. People and large objects are visible, but detailed work is still difficult.

- Basic warehouse aisles
- Industrial storage areas

3 Foot-Candles

Dim but usable indoor lighting. Safe movement is easy, though reading is not comfortable.

- Bulk storage
- Loading areas

5 Foot-Candles

Clearly lit workspace. Reading paperwork and seeing equipment details is possible, though still far below office lighting levels.

- Loading docks
- Basic production floors
- Mechanical work areas

Quick Comparison

Foot-Candles	How It Feels	Reading Ability	Typical Use
1 fc	Full moon brightness	No	Emergency/minimal
2 fc	Very dim room	Large print only	Storage
3 fc	Dim warehouse	With effort	Bulk storage
5 fc	Basic working light	Yes	Loading docks

Context for Commercial Applications

Office environments typically range from 30–50 foot-candles. Retail spaces range from 50–75 foot-candles. Precision assembly areas may exceed 75–100+ foot-candles. Therefore, 1–5 foot-candles represents very low, safety-level illumination.

Prepared by KLOO Solutions LLC – Professional Commercial Electrical Services



Everest 92 in. 1-Light Black Modern Outdoor Waterproof Integrated LED Solar Landscape Lamp Post Light with Light Bulb

<https://www.homedepot.com/p/GAMA-SONIC-Everest-92-in-1-Light-Black-Modern-Outdoor-Waterproof-Integrated-LED-Solar-Landscape-Lamp-Post-Light-with-Light-Bulb-109001/300587495#see-more-details>

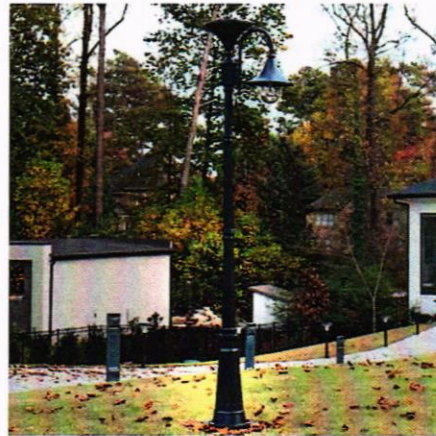

Model# 109001

\$263.99

- Dusk-to-dawn with 200 lumens in warm white color up to 3 nights
- It offers high/low mode last up to 3 nights with landscape needs
- Black solar lamp post constructed of waterproof cast aluminum

About This Product

The gama sonic everest solar post light and lamp post 109001 is a single head solar lamp post. It is a rust resistant, black cast aluminum solar lamp post which features an attractive mix of industrial elements with a bold statement of modern decor design. The everest series incorporates our cutting edge GS solar LED light bulb technology and provides direct downward illumination at a brightness of 200 Lumens. Standing 92 in. tall, this solar light with a powder coated black finish, will add style and distinction wherever it's installed. Easy to install and providing ample light this solar light is the perfect solar lighting solution for your outdoor space.

Highlights

- New solar technology: GS solar light bulb is brand new patented technology that takes the conventional idea of a light bulb and incorporates it into outdoor solar lamps and lamp posts

- Easy solar DIY solution: The Everest solar lamp post with our new solar bulb technology comes with all the hardware needed for mounting this unit anywhere you choose where ample sunshine is available
- Dusk to dawn: Gama Sonic solar powered post light and lamp post is designed to provide dusk-to-dawn performance when its battery gets fully charged during the day
- No electrical wiring: no electrical wiring is required for installation, making it the perfect energy and money saving alternative to electric or gas-powered outdoor lighting
- No maintenance is required: Gama Sonic solar powered lamp post from the Everest solar lamp series is constructed of weather-resistant, rust-resistant cast aluminum
- Solar power means no electrical wiring or utility hookups required for energy--just sunlight
- Charge times vary based on weather, but direct sunlight needed on panel for proper charging--do not install in shade
- Monocrystalline solar panels are protected by durable, cleanable tempered glass to enhance longevity and performance
- Warm white light: our Everest solar lamp post delivers warm white light, creating the natural look of incandescent light in a solar lamp setting
- We aim to make the world's best solar lights: for any product questions or unexpected issues with your Gama Sonic product, Gama Sonic support at our Atlanta headquarters is here to help at 1-800-835-4113 from 9 a.m. to 5 p.m. EST or by e-mail at support@gamasonic.com

- **Product Information**

- **Internet # 300587495**

- **Model # 109001**

Height 7'8" - (92")

Fixture Material	Aluminum
Power Source	Solar
Outdoor Lighting Features	Dusk to Dawn
Durability	Weather Resistant
Number of lights	1 light
Voltage Type	No Voltage
Exterior Fixture Type	Post & lamp set

Dimensions

Product Depth	11"
Product Height	92"
Product Width	11"

Details

Durability	Weather Resistant
Exterior Fixture Type	Post & Lamp Set
Features	Dusk to Dawn
Fixture Color/finish	Black
Fixture Material	Aluminum
Included	Hardware Included
Light Bulb Type Included	Integrated LED
Power Source	Solar
Returnable	90-days
Style	Farmhouse, Rustic
Voltage Type	No Voltage

Warranty / Certifications

Two-year limited warranty. For product support, including warranty claims, call Gama Sonic USA customer support by phone at 1-800-835-4113 from 9 a.m. to 5 p.m. Eastern time or by e-mail at support@gamasonic.com.

Sunday, March 22, 2026

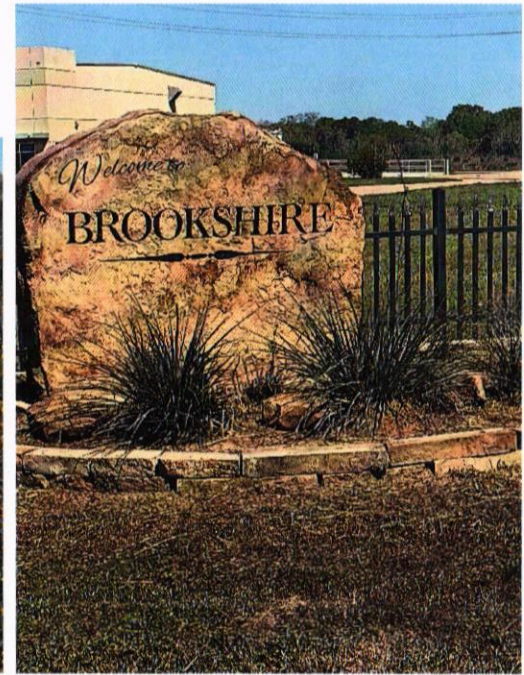
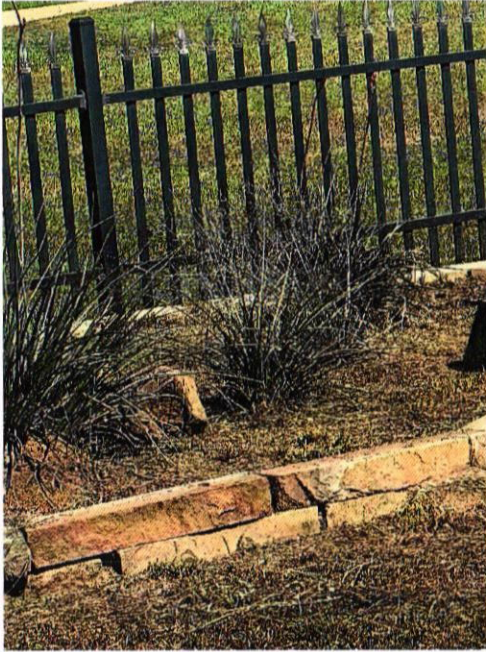

Tuesday, March 24, 2026



Recognizing Some of Our Local
Businesses That Has a Great
Partnership with the Community

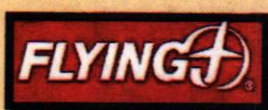

Special Speaker

Commissioner Justin Beckendorff



Commissioner Justin Beckendorff first took office on January 1, 2015, and was reelected in 2018.

You're Invited City of Brookshire Business & Expansion Program

Widening of Front Street / Hwy 90

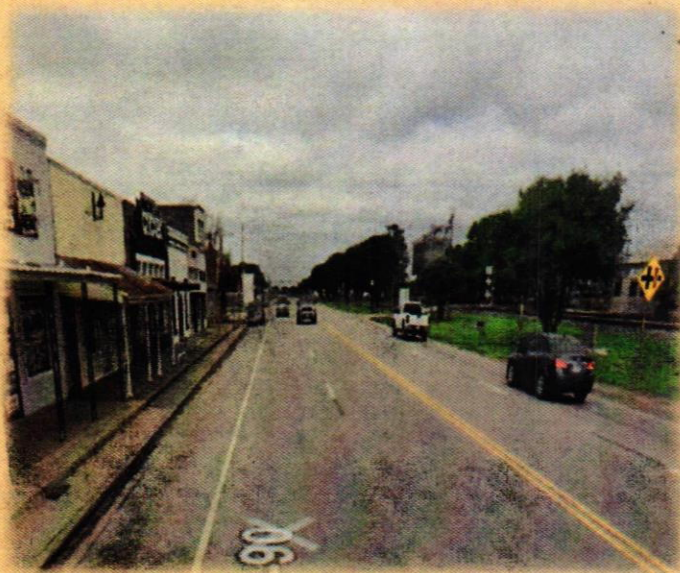

May 8th

6:00 p.m. – 8:00 p.m.

Brookshire Convention Center
41029 5th Street
Brookshire, TX

RSVP

By April 17th / 281-375-5050 ex 5016

Casual Business

Bring your business cards or useful information that can be used for networking. This is a great opportunity to learn about other local businesses and promote your own.

If you would like to have a special table for your promotion, please let us know and we will be happy to provide you with a special place.